

IRON ROCK OFF ROAD

JL Control Arm Instructions

1-877-919-JEEP www.ironrockoffroad.com

Parts Checklist:

- Iron Rock Off Road Logo Decal 10001 (1)
- Ironrockoffroad.com decal (1)

Front Lower Control Arms:

- LCA Front, 77064B (2)
 - 16mm Bushing Installed
- LCA Front, Straight Threaded male end 92186 (2)



- #65 - Adjustable LCA Clamping Hardware (1)**
 - 1/4"-28 x 1-1/8" socket head cap screw (4)
 - 1/4"-28 hex nut, gr8 (4)
- #233 - 2 5/8" 6 Bolt IRO Flex End Hardware (2)**
 - Inner race 91118 (2)
 - Thrust washer 91119 (2)
 - 2-5/8" Flex End Ball 16mm bolt 91242 (1)
 - 10-32 x 1-3/4" Socket Head Cap Screw (6)
 - 10-32 Nylock Nut (6)
 - 1/4"-28 90° Grease zerk Fitting (1)

Rear Lower Control Arms:

- LCA Rear, 80010B (2)
 - 14mm Bushing Installed
- LCA Rear, Straight Threaded male end 92186 (2)



- #65 - Adjustable LCA Clamping Hardware (1)**
 - 1/4"-28 x 1-1/8" socket head cap screw (4)
 - 1/4"-28 hex nut, gr8 (4)
- #127 - 2 5/8" 6 Bolt IRO Flex End Hardware (2)**
 - Inner race 91118 (2)
 - Thrust washer 91119 (2)
 - 2-5/8" Flex End Ball 91117 (1)
 - 10-32 x 1-3/4" Socket Head Cap Screw (6)
 - 10-32 Nylock Nut (6)
 - 1/4"-28 90° Grease zerk Fitting (1)

Front Upper Control Arms:

- UCA Front 77067 (2)
- UCA Front threaded male end 80025 (2)



- #185 - UCA Front 2" Flex End Hardware 13311 (2)**
 - End Cap 91124 (2)
 - Race 91123 (2)
 - 12mm Ball 91122 (1)
 - 5-40 X 1-1/4 SHCS (9)
 - 3/32 Hex L-key (hex plus) (1)
 - 1/4"-28 Straight grease zerk (1)
- #186 - UCA Clamping Hardware 13312 (1)**
 - 3/8-16 X 1-1/4 Hex bolt gr8 (2)
 - 3/8-16 Nylock flange nut gr8 (2)
 - 3/8 Mil spec washer (2)

Rear Upper Control Arms:

- UCA Rear 80022 (2)
- UCA Rear threaded male end, bushing installed 80023 (2)



- #168 - 2 3/8" 8 Bolt IRO Flex End Hardware (2)**
 - Inner race 91139 (2)
 - Thrust washer 91138 (2)
 - 2-3/8" Flex End Ball 91140 (1)
 - 8-32 x 1-1/2" Socket Head Cap Screw (8)
 - 90 Degree 1/4"-28 Grease Zerk Fitting (1)
- #186 - UCA Clamping Hardware 13312 (1)**
 - 3/8-16 X 1-1/4 Hex bolt gr8 (2)
 - 3/8-16 Nylock flange nut gr8 (2)
 - 3/8 Mil spec washer (2)



Before you begin:

- ***Ensure that all parts are present and in good condition using above shipping checklist. ***
- Read and understand all installation instructions.
- Tools required:
 - Floor jack and jack stands
 - Basic hand tools
 - Torque wrench
 - File or angle grinder
 - Anti-seize compound
 - Multipurpose grease



Prepare the parts for installation:

1. **Adjustable Control Arms:** Using the instructions on the last page assemble the flex ends into the threaded male ends for LCAs and into the arms for UCAs.
2. Use a light coat of anti-seize then thread the male ends into the control arms and adjust to the lengths in the chart as a starting point.
**Control arm lengths will vary depending on your lift height, tire/wheel combo.
3. Install the clamping hardware into the control arms, do not fully tighten at this time.

Control Arm Starting Length (Center to Center)		
	2" Lift	3" Lift
Front UCA (Upper Control Arm)	20-1/4"	20-1/4"
Front LCA (Lower Control Arm)	24"	24-1/4"
Rear UCA	17-3/8"	17-3/8"
Rear LCA	19-3/4"	20"

Front installation:

4. Lift front of vehicle and support with jack stands under frame rails.
**Tip: break lug nuts loose before lifting vehicle.
5. Remove front wheels
6. Support the axle with jack stands and remove shocks.
7. Remove the factory lower control arms.
8. Install new lower control arms using the factory hardware. Do not tighten bolts at this time.
The bend goes up for ground clearance and in for tire clearance. The rubber bushing goes to the axle and the flex end at the frame.
9. Remove factory upper control arms and install new upper control arms using the factory hardware. Clamping bolt facing down. Do not tighten bolts at this time.
10. Reinstall front wheels.
11. Lower vehicle onto ground.

Rear installation:

12. Lift rear of vehicle and support with jack stands under frame rails.
**Tip: break lug nuts loose before lifting vehicle.
13. Remove rear wheels.
14. Support the axle with jack stands and remove shocks.
15. Remove factory lower control arms and install new lower control arms using the factory hardware. Clamping bolts facing down, flex end at the frame, grease zerk pointed down.
16. Remove factory upper control arms and install new upper control arms using the factory hardware. Clamping bolt facing in, flex end at the frame.
*For ease of installation: it is recommended that the rear axle be set at ride height and the upper control arm bolts be torqued before install of the rear bump stop spacers.
17. Reinstall rear wheels.
18. Lower vehicle onto ground.

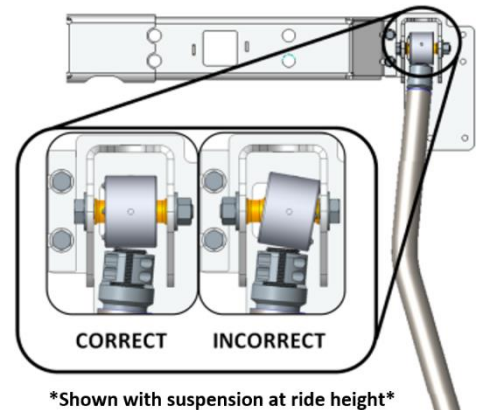

Final Torque and Adjustments:

19. With the vehicle weight on the suspension, tighten front lower control arm bolts to 130 lb-ft. Tighten front upper control arm bolts to 75 lb-ft.
20. Tighten rear upper and lower control arm bolts to 130 lb-ft.
21. Torque lug nuts to factory spec. (85 to 115 ft-lbs)
22. Ensure flex ends are parallel with control arm mounts then torque lower control arm clamping bolts to 140 in-lb. Be sure to go back and forth between both bolts several times to ensure even clamping.
23. Check all components for clearance for suspension to fully cycle up and down and wheels to turn lock to lock. Pay special attention to brake lines, axle vent hoses, and ABS wires. Reposition as needed by bending the brackets, relocating, or extending hoses and wiring.

Final Safety Warning:

* Re-torque all fasteners after 100 miles, and frequently inspect all safety critical suspension components. It is the responsibility of the installer to be sure all fasteners are properly tightened after installation and to ensure the owner knows his/her ongoing responsibility. It is the responsibility of the owner of the vehicle to be sure all safety critical components are inspected frequently, especially after off road or other demanding use.

IRON ROCK OFF ROAD

2-5/8" IRO Flex End 16mm Bolt
Assembly Instructions

1-877-919-JEEP www.ironrockoffroad.com

*****NOTE: This flex end is ONLY for the front lower control arm of the Jeep Wrangler JL and Jeep Gladiator JT. This flex end uses a larger 16mm through bolt. Do not confuse it with HK #127**

Before you begin:

- Read and understand installation instructions.
- Contact Iron Rock Off Road with any questions before, during, or after installation.
- **Ensure that all parts are present and in good condition per attached shipping checklist!**
- Have these tools handy:
 - 5/32" Allen head socket
 - 3/8" open end wrench
 - Inch-lb. torque wrench
 - Multipurpose grease/grease gun

Parts Checklist:

- Outer housing, weld on (may already be attached to your existing control arm)

#233 - 2-5/8" IRO Flex End (6 bolt)

- 2-5/8" flex end race 91118 (2)
- Thrust washer 91119 (2)
- 2-5/8" flex end ball 16mm 91242 (1)
- #10-32 nylock nut (7)
- #10-32 x 1-3/4" socket head cap screw (6)
- 90° 1/4"-28 grease zerk fitting (1)

Assembly:

1. Insert two #10-32 socket head cap screws into one thrust washer and one plastic race. Spherical bore of race facing away from thrust washer. (Figure 1)
2. Install this small assembly into the flex end housing. The races are a light press fit, use a wide punch and hammer to assist you if needed.
3. Apply a thin coating of multi-purpose grease to the mating surfaces of the ball and both races.
4. Place the ball in the race (inside the flex end). The ball should perfectly fit the contour of the race. (Figure 2)
5. Insert the other race onto the ball so that the spherical bore is contacting the ball. Once again, the races are a light press fit, use a hammer and wide punch if needed. (The two screws should be through one washer and both races at this point)
6. Insert the second thrust washer on top of the flex end housing, sliding the bolts through the holes. (Figure 3)
7. Start nylock nuts on the two bolts that are in the flex end assembly. Hold the nut and turn the bolt.
8. Insert the remaining four cap screws through the remaining holes and install nuts. (Figure 4)
9. Snug up all of the bolts fairly tight.
10. Torque bolts evenly, starting at one bolt and continuing using a crisscross pattern. Torque all six bolts to 70 in-lbs., then to 85 in-lbs.
11. Install 90° grease zerk fitting so that it is easily accessed in the vehicle.
12. Grease flex end until grease comes out of the races around the ball.
13. Re-torque bolts to 85 in-lbs. after 5 minutes.



Figure 1

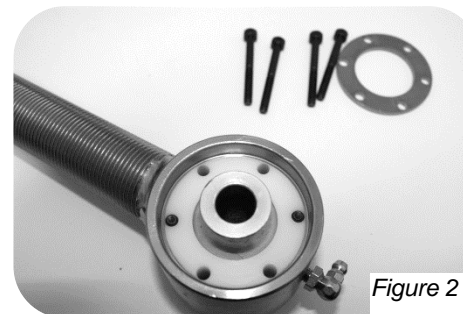

Figure 2



**Reference Only* Complete joint shown fully assembled without housing*

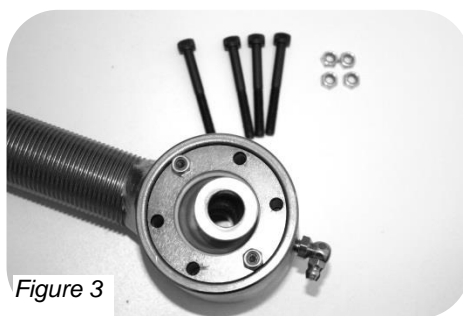

Figure 3

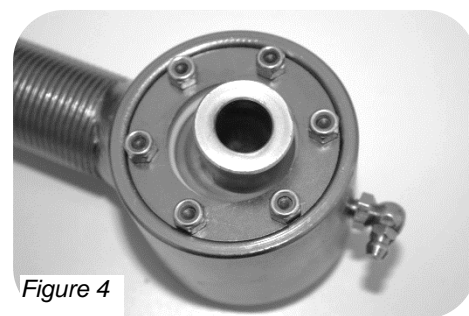

Figure 4

IRON ROCK OFF ROAD

2-5/8" IRO Flex End (6 bolt)
Assembly Instructions

1-877-919-JEEP www.ironrockoffroad.com

Fits All Iron Rock Off Road Long Arm Systems, WJ A-Arms, and Build Your Own Flex End Assemblies.

Before you begin:

- Read and understand installation instructions.
- Contact Iron Rock Off Road with any questions before, during, or after installation.
- **Ensure that all parts are present and in good condition per attached shipping checklist!**
- Have these tools handy:
 - 5/32" Allen head socket
 - 3/8" open end wrench
 - Inch-lb. torque wrench
 - Multipurpose grease/grease gun

Parts Checklist:

- Outer housing, weld on (may already be attached to your existing control arm)

#127 - 2-5/8" IRO Flex End (6 bolt)

- 2-5/8" flex end race 91118 (2)
- Thrust washer 91119 (2)
- 2-5/8" flex end ball 91117 (1)
- #10-32 nylock nut (7)
- #10-32 x 1-3/4" socket head cap screw (6)
- 90° 1/4"-28 grease zerker fitting (1)

Assembly:

14. Insert two #10-32 socket head cap screws into one thrust washer and one plastic race. Spherical bore of race facing away from thrust washer. (Figure 1)
15. Install this small assembly into the flex end housing. The races are a light press fit, use a wide punch and hammer to assist you if needed.
16. Apply a thin coating of multi-purpose grease to the mating surfaces of the ball and both races.
17. Place the ball in the race (inside the flex end). The ball should perfectly fit the contour of the race. (Figure 2)
18. Insert the other race onto the ball so that the spherical bore is contacting the ball. Once again, the races are a light press fit, use a hammer and wide punch if needed. (The two screws should be through one washer and both races at this point)
19. Insert the second thrust washer on top of the flex end housing, sliding the bolts through the holes. (Figure 3)
20. Start nylock nuts on the two bolts that are in the flex end assembly. Hold the nut and turn the bolt.
21. Insert the remaining four cap screws through the remaining holes and install nuts. (Figure 4)
22. Snug up all of the bolts fairly tight.
23. Torque bolts evenly, starting at one bolt and continuing using a crisscross pattern. Torque all six bolts to 70 in-lbs., then to 85 in-lbs.
24. Install 90° grease zerker fitting so that it is easily accessed in the vehicle.
25. Grease flex end until grease comes out of the races around the ball.
26. Re-torque bolts to 85 in-lbs. after 5 minutes.



Figure 1

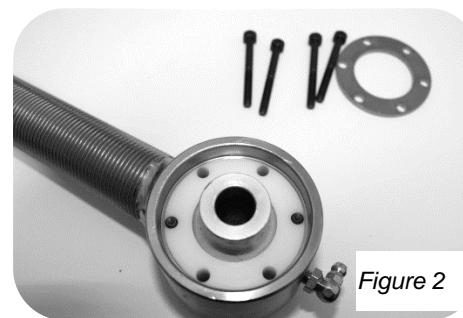
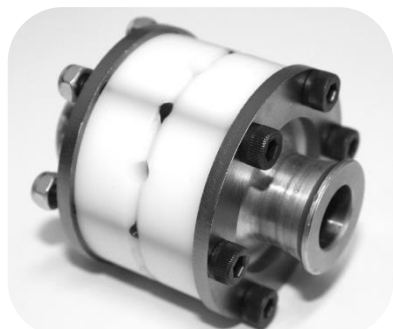

Figure 2



**Reference Only* Complete joint shown fully assembled without housing*

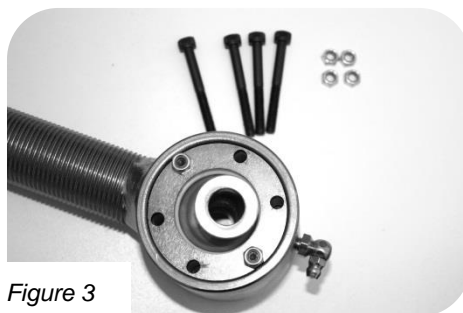

Figure 3

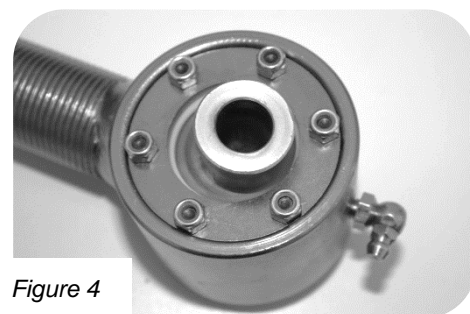

Figure 4

IRON ROCK OFF ROAD

2-3/8" IRO Flex End (8 bolt)

Assembly Instructions

1-877-919-JEEP www.ironrockoffroad.com

Before you begin:

- Read and understand installation instructions.
- Contact Iron Rock Off Road with any questions before, during, or after installation.
- **Ensure that all parts are present and in good condition per attached shipping checklist!**
- Have these tools handy:
 - 9/64" Allen head socket
 - 3/8" open end wrench
 - Inch-lb. torque wrench
 - Multipurpose grease/grease gun

Parts Checklist:

- Outer housing, weld on (may already be attached to your existing control arm)

#168 - 2-3/8" IRO Flex End (8 bolt)

- Inner race 91139 (2)
- Thrust washer 91138 (2)
- Ball 91140 (1)
- #8-32 x 1-1/2" socket head cap screw (8)
- 1/4"-28 90° grease zerk fitting (1)
- 1/4"-28 straight grease zerk fitting (1)

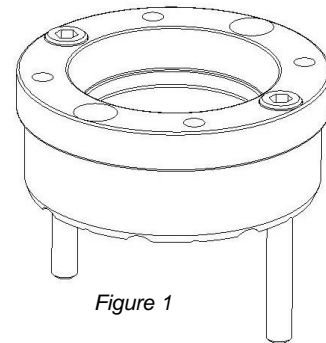
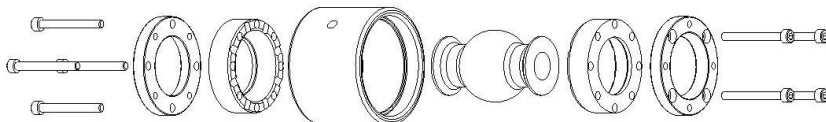
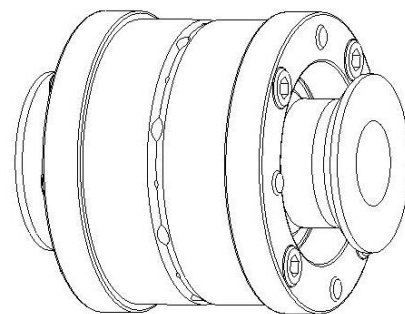

Figure 1

Assembly:

1. Insert two #8-32 socket head cap screws into one thrust washer and one plastic race. Spherical bore of race facing away from thrust washer. (Figure 1)
2. Install this small assembly into the flex end housing. The races are a light press fit, use a wide punch and hammer to assist you if needed.
3. Apply a thin coating of multi-purpose grease to the mating surfaces of the ball and both races.
4. Place the ball in the race (inside the flex end). The ball should perfectly fit the contour of the race.
5. Insert the other race onto the ball so that the spherical bore is contacting the ball. Once again, the races are a light press fit, use a hammer and wide punch if needed. (The two screws should be through one washer and both races at this point)
6. Insert the second thrust washer on top of the flex end housing, aligning the bolts with the threaded holes.
7. Start threading the two bolts into the threaded holes of the thrust washer. Do not fully tighten at this time.
8. Insert the remaining cap screws through the remaining holes and get them started in the threaded washer.
9. Snug up all of the bolts fairly tight. Go back and forth, rechecking each bolt several times to ensure even clamping
10. Torque bolts evenly starting at one bolt using a crisscross pattern, like torquing lug nuts. Torque all eight bolts to 50 in-lbs., then to 55 in-lbs.
11. Install 90° grease zerk fitting so that it is easily accessed in the vehicle.
12. Use a grease gun to grease the flex end through the zerk fitting. This will be difficult due to the tight tolerances in the flex joint assembly.
13. Re-torque bolts to 55 in-lbs.



**Reference Only* Complete joint shown fully assembled without housing*

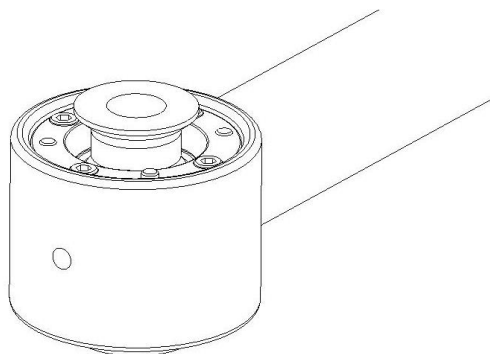

IRON ROCK OFF ROAD

2" IRO Flex End (8 bolt)

1-877-919-JEEP www.ironrockoffroad.com

Assembly Instructions

Fits All Iron Rock Off Road Long Arm Systems and Build Your Own Flex End Assemblies.

Parts Checklist:

- Optional: 10676** **#140 – 2" Flex Joint 8-Bolt 10mm Weld-on (1)**
 - End cap 91124 (2)
 - Race 91123 (2)
 - 5-40 x 1-1/4" socket head cap screw (9)
 - 3/32" Hex L key, high torque (hex plus) (1)
 - 2" flex end ball 10mm, 8 bolt, 91121 (1)
 - Outer housing, weld on (may already be attached to your existing control arm)

- Optional: 10677** **#141 – 2" Flex Joint 8-Bolt 10mm Press In (1)**
 - End cap 91124 (2)
 - Race 91123 (2)
 - 5-40 x 1-1/4" socket head cap screw (9)
 - 3/32" Hex L key, high torque (hex plus) (1)
 - 2" flex end ball 10mm, 8 bolt, 91121(1)
 - Outer housing, press in 91078 (1)

- Optional: 10678** **#142 – 2" Flex Joint 8-Bolt 12mm Weld-on (1)**
 - End cap 91124 (2)
 - Race 91123 (2)
 - 5-40 x 1-1/4" socket head cap screw (9)
 - 3/32" Hex L key, high torque (hex plus) (1)
 - 2" flex end ball 12mm, 8 bolt, 91122 (1)
 - Outer housing, weld on (may already be attached to your existing control arm)

- Optional: 10679** **#143 – 2" Flex Joint 8-Bolt 12mm Press In (1)**
 - End cap 91124 (2)
 - Race 91123 (2)
 - 5-40 x 1-1/4" socket head cap screw (9)
 - 3/32" Hex L key, high torque (hex plus) (1)
 - 2" flex end ball 12mm, 8 bolt, 91122 (1)
 - Outer housing, press in 91078 (1)

- Optional: 10680** **#144 – 2" Flex Joint 8-Bolt 1/2" Weld-on (1)**
 - End cap 91124 (2)
 - Race 91123 (2)
 - 5-40 x 1-1/4" socket head cap screw (9)
 - 3/32" Hex L key, high torque (hex plus) (1)
 - 2" flex end ball 1/2", 8 bolt, 91126 (1)
 - Outer housing, weld on (may already be attached to your existing control arm)

- Optional: 10681** **#145 – 2" Flex Joint 8-Bolt 1/2" Press In (1)**
 - End cap 91124 (2)
 - Race 91123 (2)
 - 5-40 x 1-1/4" socket head cap screw (9)
 - 3/32" Hex L key, high torque (hex plus) (1)
 - 2" flex end ball 1/2", 8 bolt, 91126 (1)
 - Outer housing, press in 91078 (1)

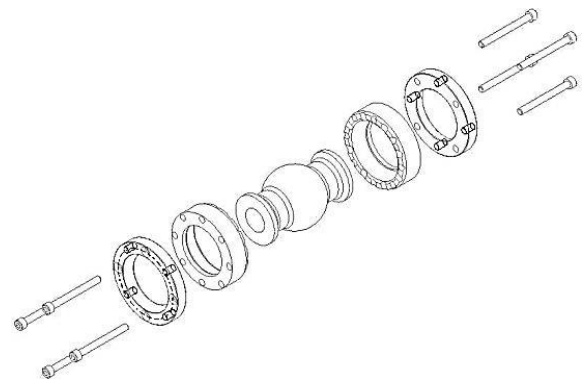

Before you begin:

- Read and understand installation instructions.
- Contact Iron Rock Off Road with any questions before, during, or after installation.
- **Ensure that all parts are present and in good condition per attached shipping checklist!**

Assembly:

1. Install outer tube (weld on or press in).
2. If using the press-in replacement for OEM rubber bushings:
 - a. Remove the existing bushing using a hammer and punch. If necessary punch the inner sleeve out first, then the rubber, then cut through the metal outer sleeve with a metal cutting blade on a Sawzall, then remove the metal outer shell.
 - b. To install the new press-in outer tube, our installation tool (sold separately) is highly recommended. See installation tool instructions for proper tool use.
 - c. If not using the Iron Rock installation tool, precaution must be taken to avoid damaging the precision machined inner surfaces. Using a bearing race and seal driver press the outer tube into the axle housing or control arm. In order to avoid damage to the precision parts, use the minimum amount of force needed to complete the job. Ensure the tube is fully seated in place. Using a hammer and punch (3/8" diameter punch works well), bend the thin edge on the flex end tube outward to lock it in place. (Use roughly 3/8" wide bends in two places.)
3. Insert two 5-40 socket head cap screws into one end cap and one race. Spherical bore of race facing away from end cap.
4. Install this small assembly into the flex end housing. The races are a tight fit, use a hammer and a wide punch to assist you if needed.
5. Apply a thin coating of multi-purpose grease to the mating surfaces of the ball and both races.
6. Place the ball in the race (inside the flex end). The ball should perfectly fit the contour of the race.
7. Insert the other race onto the ball so that the spherical bore is contacting the ball. Once again, the races are a tight fit, use a hammer and wide punch if needed. (The two screws should be through one washer and both races at this point).
8. Insert the second end cap in the flex end housing, sliding the bolts through the holes.
9. Start threading the two bolts that are in the flex end assembly.
10. Insert the remaining six cap screws through the remaining holes.
11. Snug up all of the bolts fairly tight.
12. Torque bolts evenly starting at one bolt using a crisscross pattern, like torquing lug nuts. Torque all eight bolts to 20 in/lbs.

