

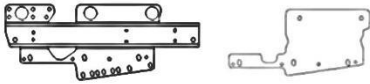

**Parts List:**

- Instructions
- Iron Rock Off Road logo decal (2)
- Ironrockoffroad.com decal (1)
- Belly skid plate 85046 (1)
- Left long arm frame mount 85104 (1)
- Right long arm frame mount 85105 (1)
- Left LCA mount gusset plate 85130 (1)
- Right LCA mount gusset plate 85131 (1)



- Transmission crossmember 85059 (1)
- Left skid plate drop bracket 85072 (1)
- Right skid plate drop bracket 85071 (1)
- Belly skid drop plate 85073 (8)
- Crossmember drop plate 85093 (8)
- Rear axle truss customer specific:
  - Optional: Dana 35 88123 (1)
  - Optional: Dana 44 88125 (1)
  - Optional: Ford 8.8 85060 (1)
- Rear 4-link truss mount 88131 (1)
- Front driver UCA 85106 (1)
- Front driver LCA 85107 (1)
- Front passenger LCA 85108 (1)
- Rear UCA 85079 (2)
- Rear driver LCA 85109 (1)

- Rear passenger LCA 85110 (1)
- Straight long arm male end 92186 (5)
- Angled long arm male end 91109 (2)
- 3/16" steel brake line tubing (5 feet)
- T-case linkage relocation plate 88134 (1)
- T-case linkage U-bracket 88135 (1)

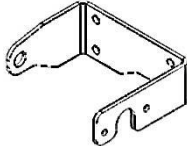

- #155 Subframe Hardware (1)**
  - 1/2-13x1-1/2" Flat head cap screw (6)
  - 3/8-16 x 1 Flat head cap screw (18)
  - 3/8-16 Serrated flange nut (18)
  - M14 X 95 hex bolt cl10.9 (3)
  - M14 hex nut cl10.9 (3)
  - 1/2 USS washer (6)
  - M10 X 80 hex bolt cl10.9 (1)
  - M10 Nylock nut (1)
  - 3/8" USS washer (2)
- #119 Transfer Case Linkage Relocation Bracket Hardware (1)**
  - 1/4-20 x 3/4 splined carriage bolt (3)
  - 1/4 USS washer (3)
  - 1/4-20 hex nut (3)
  - 1/4-20 x 3/4 thread cutting screw (2)
  - Linkage bushing 53004810 (1)
- #120 Belly Skid Drop Hardware (1)**
  - 3/8-16 x 1-1/4 Carriage bolt (8)

- 3/8-16 x 2 Flat head cap screw (10)
- #124 Fuel Line Clamps / Cable Ties (1)**
  - 8" cable tie (8)
  - 1/4 x 1 hex head self-drilling screw (5)
  - 3/4" rubber cushioned loop clamp, stainless steel CLAMP 25612 (3)
- #127 Flex End Hardware (9)**
  - 2 5/8 Flex End Race 91118 (2)
  - Thrust washer 91119 (2)
  - 2 5/8 Flex End ball 91117 (1)
  - 10-32 nylock nut (7)
  - 10-32 x 1 3/4 socket hd cap screw (6)
  - 90 Degree 1/4"-28 grease zerk (1)
- #128 Rear bump stop spacer (1)**
  - 3" bump stop spacer MB03 (2)
  - M10 x 100 hex bolt (2)
  - 3/8 USS washer (2)
- #147 TJ Rear Brake Line hardware (1)**
  - 3/16" brake line flare nut (4)
  - 7/16 x 1.25 gr8 hex bolt (1)
  - 7/16-14 gr8 hex bolt (1)
- #148 TJ Control Arm Clamp Bolts (1)**
  - 1/4-28 x 1 1/4 Socket hd cap screw (14)
  - 1/4-28 hex nut gr8 (14)
- #150 Rear Truss Hardware (1)**
  - M14 x 100 Hex bolt, CL10.9 (2)
  - 1/2 USS washer (2)
  - M14 unplated hex nut, CL10.9 (2)

## **Safety Warning: \*\*\*Important! Read before installation.\*\*\***

Installing a suspension lift kit raises the center of gravity of the vehicle. This increases the possibility of a rollover accident. Avoid sudden maneuvers at high speed and avoid all situations where a side rollover may occur. In addition larger tires decrease braking performance, please drive accordingly. We recommend a tire and wheel combination that makes the vehicle's track width wider (wheels with less backspacing than OEM). This will lower the center of gravity and add stability. We also recommend that this system be installed by a qualified professional. Knowledge of suspension component function is necessary for safe installation and post installation inspections. Be sure to re-torque all suspension components after the first 100 miles of use, and frequently inspect all safety critical suspension components.

## **Before you begin:**

- Read all safety warnings.
- Read and understand installation instructions.
- Check all steering and suspension components for wear and replace as needed.
- Contact Iron Rock Off Road with any questions before, during, or after installation.
- Ensure that all parts are present and in good condition using the included shipping checklist.

## **Installation of this suspension system:**

- Requires cutting, grinding, welding, and fabricating.
- Requires removal of most suspension mounts from the frame. Returning the vehicle to stock will not be possible after installation.
- Requires an Iron Rock or custom exhaust system.
- Requires a 4 wheel alignment.
- Requires a transfer case slip yoke eliminator and custom CV driveshaft after installation. "Super short" slip yoke eliminator is highly recommended.
- Iron Rock OTK steering highly recommended.
- 1" motor mount lift highly recommended.
- Trimming of cooling fan shroud may be required.
- Extended axle breather tubes may be required.

## **Be sure you have the following tools and supplies:**

- Floor jack and a minimum of 7 jack stands (or an automotive lift)
- Basic hand tools
- Multi-purpose grease (all poly bushings should be greased before installation)
- Anti-seize compound
- Hand drill & 3/8" drill bit
- Angle grinder with grinding, sanding, and cut off wheels
- Sawzall
- Welder
- Brake line bender
- Double flaring tool (for brake lines)

## **Prepare the parts for installation:**

Control Arm Length (Center to Center)	
Front UCA (Upper Control Arm)	37 7/8" (Short Side)
Front LCA (Lower Control Arm)	38" (Short Side)
Rear UCA	37 3/8" (Short Side)
Rear LCA	37 5/8" (Short Side)

1. Locate all seven control arms, and hardware kit 127&148. Build control arms: Assemble flex ends per attached instructions (last page). Adjust lengths per the chart as a starting point. Install and tighten clamping bolts. Rear lower arms use angled male ends; all others use straight male ends. See figures 1-4.

## **Disassembly:**

2. Lift front and rear of vehicle and support with jack stands under the frame near the lower control arm mounts.  
\*\*Tip: break lug nuts loose before lifting vehicle.
3. Ensure that vehicle is safely supported.
4. Remove front and rear tires.
5. Place two jack stands under the front axle tubes and one under the pinion.
6. Disconnect front driveshaft. Wrap tape around u-joint caps so they don't fall off.
7. Remove front control arms. Save hardware for re-use.
8. Place two jack stands under rear axle tubes and one under the pinion (just for support, do not lift axle).
9. Remove rear shocks.
10. Remove rear track bar.
11. Remove rear sway bar links. Save hardware for later use.
12. Remove rear driveshaft.
13. Remove rear brake hose and temporarily cap hard line at frame.
14. Disconnect emergency brake cables.
15. Disconnect axle breather tube.
16. Remove rear coil springs.
17. Remove rear control arms. Save hardware for re-use.
18. Set rear axle assembly aside.
19. Remove the four transfer case/ tranny mount nuts in the center of the belly skid.



**Figure 1**  
Front Upper Control Arm

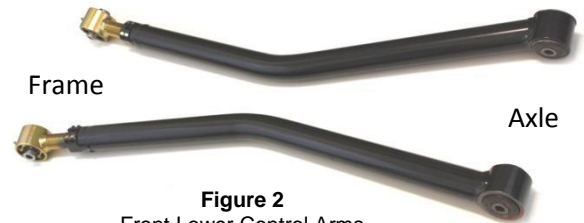

**Figure 2**  
Front Lower Control Arms



**Figure 3**  
Rear Upper Control Arms



**Figure 4**  
Rear Lower Control Arms

20. Raise transfer case slightly and support with jack stand.
21. Rubicon models: unbolt differential locking air compressor bracket from the skid plate.
22. Unbolt and remove factory belly skid plate.

### **Frame Prep:**

23. Cut exhaust 1" behind the 90 degree bend, after the exhaust crosses under the oil pan (to the passenger side), leaving approx. 1" of straight pipe. An Iron Rock or custom exhaust system is required to clear the control arms and skid plate. The factory exhaust will no longer fit.
24. Remove disconnected exhaust system from the vehicle.
25. These brackets must be cut off of the frame:
  - Front driver side LCA (lower control arm)
  - Front pass. side LCA
  - Rear driver side UCA (upper control arm)
  - Rear driver side LCA
  - Rear pass. side UCA
  - Rear pass. side LCA
  - Front driver side UCA mount; 6 cylinder models remove entire bracket, 4 cylinder models remove lower portion of bracket using attached template (figure 17).
26. Optionally, you may choose to remove the rear track bar mount as well.
27. Remove brackets and grind any remaining material until flush and smooth. Be very careful not to cut into the frame itself.
28. Prime and paint the bare metal to prevent rust and leave an attractive finish.
29. Cut off the front heat shield mounting bolt (above catalytic converter location) flush to the bottom of the nut for frame bracket clearance.
30. On LJ Unlimited models: Cut off the bolt that hangs down above the rear axle, directly above the rear upper control arms (axle end). Cut the bolt flush to the bottom of the nut.



**Figure 5**  
Exhaust after cutting

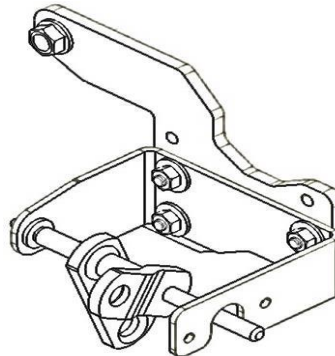

**Figure 6**  
Transfer Case Linkage



**Figure 7**  
Transfer Case Linkage Installed

### **Long Arm Mounting Subframe:**

31. Remove any rust or other debris from bottom of frame (above the belly skid) to provide a solid, flat mounting surface for your new long arm brackets. Prime and paint any bare metal.
32. Remove most fuel line retaining clips from the driver's side frame. Anything between the front upper control arm mount and the rear coil spring mount should be removed and discarded.
33. Using the insulated clamps and self-drilling screws in hardware kit 126, reposition fuel and brake lines above the frame (see figure 8). Leave wiring out of the clamps and fasten to the steel lines using cable ties.
34. Locate transfer case linkage u-bracket, mounting plate, and hardware kit 119 (figure 6).
35. Install splined carriage bolts into flat plate from the backside into the lower set of holes. Use a press, bench vice, or hammer to press them in.
36. Disconnect both transfer case linkage rods from the pivot arm. Use a pry bar to pop the linkage out of its bushings. Disconnect all linkage from the pivot arm and remove pivot arm from its mounting brackets.
37. Install the pivot arm into the provided u-shaped bracket using the new bushing and thread cutting screws. Tighten screws.
38. Remove the 2 nuts that hold the linkage bracket to the transfer case and remove bracket. Install the new flat plate in its place (figure 7). Tighten nuts.
39. Remove factory linkage bracket from body tub. Cut above the lower bolts (using a sawzall or abrasive wheel) and the bracket will slide out without removing the bolts. Leave the rubber mounts in place.
40. Bolt the u-bracket to the flat plate using a washer under each nut. Tighten nuts.
41. Connect all linkage rods at this time. Adjust primary linkage rod so that the transfer case will reach all positions without binding. Be sure there is a little bit of extra travel, or wiggle room, beyond the front and rearmost positions (2 high and 4 low).
42. Locate the lower control arm mounting bracket, gusset plates, and hardware kit 155 (see figure 11). Assemble the control arm mount gusset plates onto the control arm mounts using four 3/8 x 1 flat head cap screws and flange nuts per side. There is a left and right for each part. Ensure the countersinks match up to the bolts for a flush finished product. Tighten bolts.
43. Install control arm mounting brackets to the frame (see figure 11 for front to rear orientation). Make sure mounting surface is flat and free of debris. Use the 1/2-13x1-1/2" flat head bolts from hardware kit 155. Use high strength threadlocker and tighten the bolts very tight.
44. Attach the crossmember to the transmission mount using the factory nuts (see figure 10). Do not tighten at this time.



**Figure 8**  
Fuel line routing

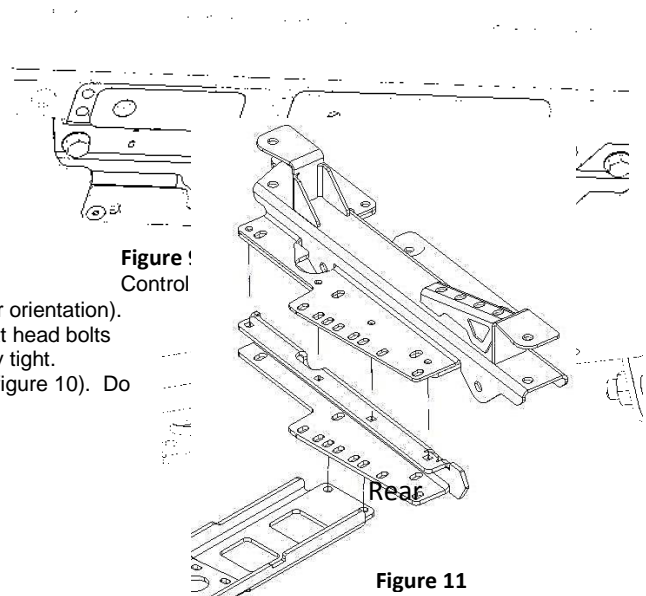

**Figure 11**  
Control

**Figure 11**

### **Adjust belly height:**



45. The belly height in this kit is extremely adjustable. Anything from a flat belly to 3" drop can be achieved using a combination of spacer plates and spacer brackets (see figure 10, 11 and 12). Flat belly configuration will require a body lift or floor pan modification. Many late model transmissions will require a 2" drop bracket (see figure 11). That's still 1.5" higher than stock. Hardware kit 120 contains the longer bolts needed for the drop spacers.
46. Bolt the crossmember to the frame mounts using the 3/8" flat head bolts and flange nuts from hardware kit 118 or 120. Use a combination of spacer plates or brackets and floor pan massaging to achieve your desired belly height.
47. Be sure to check the electrical wiring located above the transmission and transfer case and relocate as needed to avoid pinching the wires.
48. Tighten all crossmember and tranny mount bolts at this time.

### **Front Suspension:**

49. Install new control arms. Re-use hardware for LCA's. UCAs get new bolts, nuts and washers from hardware kit 118. \*\*\*Front upper control arm bolt (at frame) may require minor clearancing of the floor pan with a pry bar. You need at least a 3/8" gap above the bolt.\*\*\*
50. Raise vehicle and reposition jack stands under the front axle.
51. Ensure the vehicle is safely supported.
52. Any remaining loose bolts will be torqued after rear suspension installation.

### **Rear Suspension:**

53. Remove hard brake lines from axle and cover caliper holes to keep dirt out.
54. Cut UCA mounts and track bar mount off of axle. Grind flush. Be careful not to cut into the axle tubes.
55. Weld upper truss bracket to truss (see figure 14). Be sure holes are aligned and leave 2 5/8" plus wiggle room for mounting control arms.
56. Assemble UCA mounting bolts and nuts from hardware kit 150 onto truss (see figure

- 14 & 15). Snug bolts and weld nuts to truss.
57. Set truss on axle and align back of the truss parallel to the differential cover mounting surface.
58. Tack weld truss to axle with bottom edge of truss is sitting approx. 1/8" above the centerline of axle tubes.
59. Fully weld truss to axle. Weld one section in each corner of the truss and continue working around the truss to avoid excess heat buildup. **Be sure to weld the vertical bend reliefs on the front and back side of the truss.**
60. Clean, prep, and paint truss. Allow to dry.
61. Mount rear brake hose to the front side of the truss (see figure 16).
62. Run new hard lines from brake T-fitting to wheel cylinders (see figure 16).
63. Place axle under the Jeep.
64. Install upper control arms with bend hanging down to clear the floor pan (adjustable threaded end at frame). Use M14 x 95 bolts, nuts, and washers (from hardware kit 118) at frame. Use M14 x 100 bolts and washers at axle (from hardware kit 150).
65. Install lower control arms. Adjustable threaded end at frame. \*\*\*Angled male ends to be angled towards the outside of the vehicle when installed.\*\*\* Bends are angled upward for ground clearance and inward to clear the frame. Re-use factory hardware.
66. Install 3" bump stop spacers (hardware kit 128) between bump stop cup and frame mount.
67. Install coil springs, rotate them until they sit as straight as possible (low spot of spring aligned to high side of spring pad).
68. Install shocks.
69. Reconnect emergency brake cables.
70. Install slip yoke eliminator kit (except Rubicon models) and custom rear driveshaft (sold separately).
71. Raise vehicle and reposition jack stands under the rear axle. Ensure the vehicle is safely supported.
72. Bleed brakes at all 4 corners.
73. Adjust suspension alignment, axle position front to rear, pinion angle, caster angle, axle centering, etc... by adjusting control arm lengths as needed.
74. Torque all M14 control arm nuts to 120 foot pounds. Torque front upper control arm nut at axle to 70 foot pounds (new bolt and nut, factory spec. is lower).
75. Torque any remaining loose bolts to spec.
76. If not already done, install front coil spring retainers.
77. Install belly skid plate using 3/8 flat head cap screws and flange nuts from hardware kit 118 and/or 120, and spacer plates as needed (see figure 13).
78. Tighten belly skid bolts.
79. Install tires.
80. Lower vehicle.
81. Torque lug nuts to spec. (85-115 foot pounds depending on your wheels)

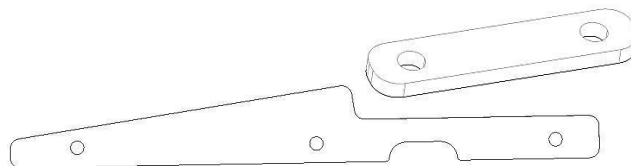

**Figure 12**  
Crossmember drop and belly skid drop plates

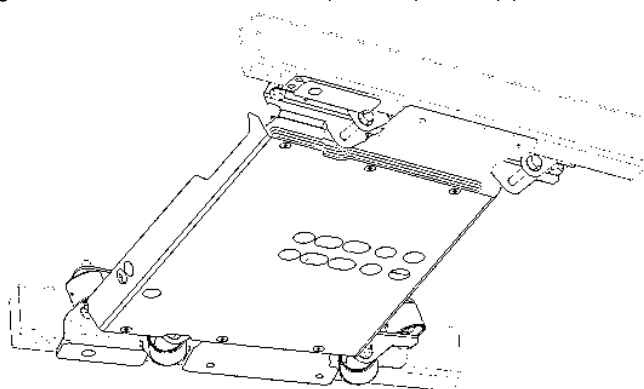

**Figure 13**

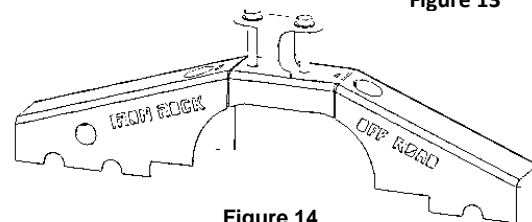

**Figure 14**

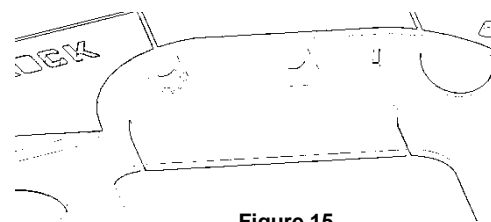

**Figure 15**

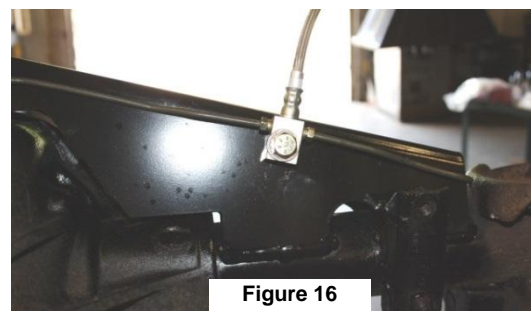

**Figure 16**

### **Adjustments and Final Inspection:**

109. Check all components for clearance for suspension to fully cycle up and down and wheels to turn lock to lock. Pay special attention to brake lines, axle vent hoses, and ABS wires. Reposition as needed by bending the brackets, relocating, or extending hoses and wiring.  
\* A professional four wheel alignment is required after installation. We recommend the following alignment settings:  
**Caster angle:** +3.75 to +5.75 degrees (+4.5 is preferred if possible) **Toe-in (front):** +1/16" to +1/8"
110. Install custom exhaust system or Iron Rock exhaust system (sold separately), or bring to an exhaust shop of your choice.

111. Trim cooling fan shroud as needed to clear the fan. If you are installing motor mount spacers, do so before trimming shroud.

**Final Safety Warning:**

\* Re-torque all fasteners after 100 miles, and frequently inspect all safety critical suspension components. It is the responsibility of the installer to be sure all fasteners are properly tightened after installation and to ensure the owner knows his/her ongoing responsibility. It is the responsibility of the owner of the vehicle to be sure all safety critical components are inspected frequently, especially after off road or other demanding use.

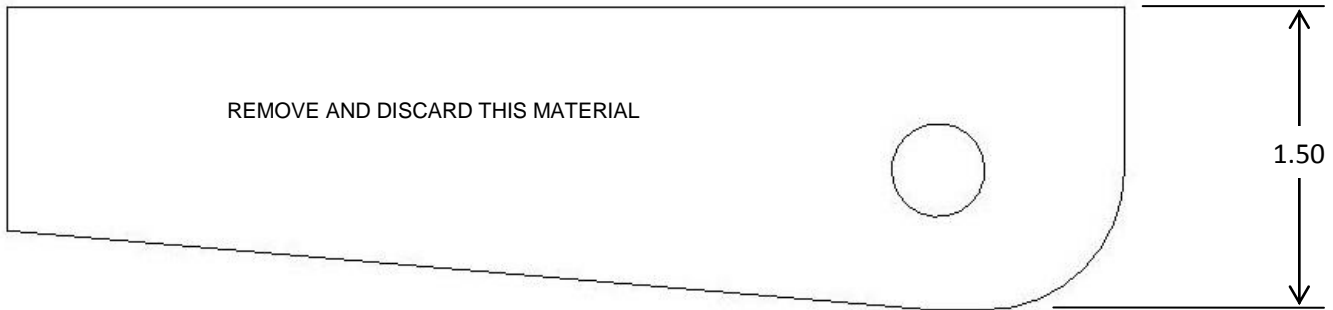

**Figure 17**  
Upper control arm mount cutting template  
(Driver's side at frame, 4 CYLINDER MODELS  
ONLY)

**IRON ROCK OFF ROAD**  
**2 5/8" IRO Flex End (6 bolt)**  
**Assembly Instructions**  
I-877-919-JEEP [www.ironrockoffroad.com](http://www.ironrockoffroad.com)

## Parts Checklist:

- Outer housing, weld on (may already be attached to your existing control arm)

### #127 - 2 5/8" 6 Bolt IRO Flex End Hardware

- Inner race 91118 (2)
- Thrust washer 91119 (2)
- Ball 91117 (1)
- 10-32 x 1-1/4" Socket Head Cap Screw (6)
- 10-32 Nylock Nut (6)
- 90 Degree 1/4"-28 Grease Zerk Fitting (1)

## Before you begin:

- o Read and understand installation instructions.
- o Contact Iron Rock Off Road with any questions before, during, or after installation.
- o **Ensure that all parts are present and in good condition per attached shipping checklist!**
- o Have these tools handy:
  - o 5/32 allen head socket
  - o 3/8 open end wrench
  - o Inch-lb. torque wrench



## Assembly:

1. Insert two 10-32 socket head cap screws into one thrust washer and one plastic race. Spherical bore or race racing away from thrust washer.
2. Install this small assembly into the flex end housing. The races are a light press fit, use a wide punch and hammer to assist you if needed.
3. Apply a thin coating of multi-purpose grease to the mating surfaces of the ball and both races.
4. Place the ball in the race (inside the flex end). The ball should perfectly fit the contour of the race.
5. Insert the other race onto the ball so that the spherical bore is contacting the ball. Once again, the races are a light press fit, use a hammer and wide punch if needed. (The two screws should be through one washer and both races at this point)
6. Insert the second thrust washer on top of the flex end housing, sliding the bolts through the holes.
7. Start Nylock nuts on the two bolts that are in the flex end assembly. Hold the nut and turn the bolt.
8. Insert the remaining four cap screws through the remaining holes and install nuts.
9. Snug up all of the bolts fairly tight.
10. Torque bolts evenly starting at one bolt using a crisscross pattern, like torqueing lug nuts. Torque all six bolts to 70 in/lbs., then to 85 in/lbs.
11. Install 90 Degree grease zerk fitting so that it is easily accessed in the vehicle.
12. Grease flex end until grease comes out of the races around the ball.
13. Re-torque bolts to 85 in-lbs. after 5 minutes.

