

IRON ROCK OFF ROAD

XJ 4-Link Rear

1-877-919-JEEP www.ironrockoffroad.com

Long Arm Instructions

Parts Checklist:

- Iron Rock Logo Decal 10001 (2)
- Rock-Link Decal 13287 (2)
- ironrockoffroad.com Decal (1)
- LCA/UCA Mounting Subframe 91162 (1)
- Shock crossmember 91173 (1)
- Shock crossmember spacer 91178 (2)
- Coil retainer upper spacer 91193 (2)
- Coil retainer middle spacer 91194 (6)
- Coil retainer lower 91192 (2)
- XJ front bumpstop 52004295 (2)
- XJ rear long UCA 91184 (2)
 - 2-3/8" flex end male end 91191 (2)
- XJ left rear long LCA 91185 (1)
- XJ right rear long LCA 91186 (1)
 - Long Arm Male End; Angled 91109 (2)
- Shock mount 99060 (2)
- Rear axle truss customer specific:
 - Optional:** D35 4 link Truss 91222 (1)
 - Axle UCA mount base 91169 (1)
 - Axle mount UCA plate inner 91170 (2)
 - Axle mount UCA plate outer 91171 (2)
 - D35 Truss Gusset 91223 (1)
 - Coil spring pad 91219 (2)
 - Left LCA bracket 91221 (1)
 - Right LCA bracket 91220 (1)
 - #184 – T-Block Eliminator (1)
 - Optional:** Chrysler 8.25" 4 link Truss 88208 (1)
 - Axle UCA mount base 91169 (1)
 - Axle mount UCA plate inner 91170 (2)
 - Axle mount UCA plate outer 91171 (2)
 - Chrysler 8.25" Truss Gusset 88262 (1)
 - Coil spring pad 99061 (2)
 - Left LCA bracket 85006 (1)
 - Right LCA bracket 85005 (1)
 - #184 – T-Block Eliminator (1)
 - Optional:** Ford 8.8" Truss 85060 (1)
 - Gusset Bracket 91224 (1)
 - Axle UCA mount base 91169 (1)
 - Axle mount UCA plate inner 91170 (2)
 - Axle mount UCA plate outer 91171 (2)
 - Coil spring pad 99061 (2)
 - Left LCA bracket 85006 (1)
 - Right LCA bracket 85005 (1)
 - Optional:** Dana 60 Over Diff Cradle 88217 (1)
 - Front Truss Plate 88218 (1)
 - Rear Truss Plate 88219 (1)
 - UCA Inner Plate 91200 (2)
 - UCA Outer Plate 91201 (2)
 - Coil spring pad 99061 (2)
 - Left LCA bracket 85006 (1)
 - Right LCA bracket 85005 (1)
 - Optional:** GM Corp. 14 Bolt Over Diff Cradle 91196 (1)
 - Front Truss Plate 91197 (1)
 - Rear Plate Left 91198 (1)
 - Rear Plate Right 91199 (1)
 - UCA Inner Plate 91200 (2)
 - UCA Outer Plate 91201 (2)
 - Coil spring pad 99061 (2)
 - Left LCA bracket 85006 (1)
 - Right LCA bracket 85005 (1)

- Optional:** JK Dana 44 Over Diff Cradle 88217 (1)
 - Front Truss Plate 88257 (1)
 - Rear Truss Plate 88256 (1)
 - UCA Inner Plate 91200 (2)
 - UCA Outer Plate 91201 (2)
 - Coil spring pad 99061 (2)
 - Left LCA bracket 85006 (1)
 - Right LCA bracket 85005 (1)
- Optional:** Ford 9" Semi-Universal Truss 88266 (1)
 - Front Truss Plate 88269 (1)
 - Rear Truss Plate 88270 (1)
 - UCA Inner Plate 88267 (2)
 - UCA Outer Plate 91201 (2)
 - Coil spring pad 99061 (2)
 - Left LCA bracket 85006 (1)
 - Right LCA bracket 85005 (1)
- Optional:** Universal Truss 88266 (1)
 - Front/Rear Truss Plate 88268 (2)
 - UCA Inner Plate 88267 (2)
 - UCA Outer Plate 91201 (2)
 - Coil spring pad 99061 (2)
 - Left LCA bracket 85006 (1)
 - Right LCA bracket 85005 (1)
- Optional:** Sterling 10.5 Truss 88298 (1)
 - Front Truss Plate 88310 (1)
 - Rear Truss Plate 88311 (1)
 - UCA Inner Plate 91200 (2)
 - UCA Outer Plate 91201 (2)
 - Coil spring pad 99061 (2)
 - Left LCA bracket 85006 (1)
 - Right LCA bracket 85005 (1)
- Lower coil spring retainer spacer plate 99054 (4)
- Upper coil spring retainer clamping plate 99059 (2)
- XJ front coil spring isolator 52000229 (2)
- 3/16" steel brake line tubing (5 ft.) (1)

#174 – XJ Rear 4-Link Crossmember Hardware (1)

- 2-hole nut plate 92097 (4)
- 7/16"-14 x 1-1/4" hex bolt, gr8 (8)
- 7/16" F436 washer (8)

#65 – Adjustable LCA Clamping Hardware (2)

- 1/4"-28 x 1-1/8" socket head cap screw (4)
- 1/4"-28 hex nut, gr8 (4)

#127 – 2-5/8" IRO Flex End (2)

- 2-5/8" flex end race 91118 (2)
- Thrust washer 91119 (2)
- 2-5/8" flex end ball 91117 (1)
- #10-32 nylock nut (7)
- #10-32 x 1-3/4" socket head cap screw (6)
- 90° 1/4"-28 grease zerk fitting (1)

#147 – XJ/TJ Rear Brake Line Hardware (1)

- 3/16" brake line flare nut (4)
- 7/16"-14 x 1.25 hex bolt, gr8 (1)
- 7/16"-14 hex nut, gr8 (1)

#167 – XJ Rear 4-Link Spring/Shock Crossmember Hardware (1)

- 3/8"-16 x 1-1/4" hex bolt, gr8 (8)
- 3/8" USS washer (8)
- 3/8"-16 rivet nut, steel (8)
- M8-1.25 x 30 hex bolt (4)
- 1/4" USS washer (4)

#168 – 2-3/8" Flex End (4)

- End cap 91138 (2)
- Inner race 91139 (2)
- Flex end ball 91140 (1)

- #8-32 x 1-1/2" socket head cap screw (8)
- 1/4"-28 90° grease zerk fitting (1)
- 1/4"-28 straight grease zerk fitting (1)

#169 – XJ Upper Rear Coil Retainer Hardware (1)

- 1/2"-13 x 3" gr5 hex bolt, fully threaded (2)
- 1/2"-13 x 5" gr5 hex bolt, fully threaded (2)

#170 – XJ Lower Rear Coil Retainer Hardware (1)

- 1/2"-13 x 1-1/2" carriage bolt (2)
- 1/2"-13 hex nut (2)

#171 – XJ 4-Link Rear Control Arm Hardware (1)

- M14 x 95 hex bolt cl10.9 (4)
- M14 x 100 hex bolt cl10.9 (8)

Installation Instructions:

Safety Warning: *Important! Read before installation*****

We recommend that this system be installed by a qualified professional. Knowledge of suspension component function is necessary for safe installation and post installation inspections. Be sure to re-torque all suspension components and lug nuts after the first 100 miles of use, and frequently inspect all safety critical suspension components.

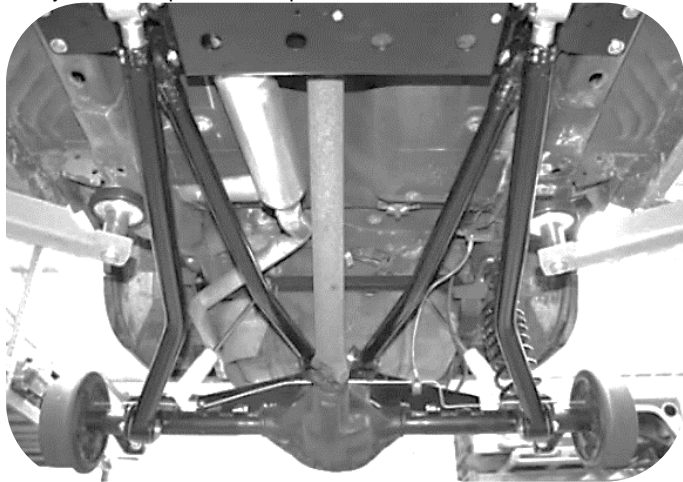

- M14 nylock nut cl10.9 (8)
 - 9/16 F436 hardened washer (8)
- #172 – XJ Rear 4-Link Shock Hardware (1)**
- M12 x 1.49" shock sleeve 404379 (4)
 - M12-1.75 x 60 hex bolt cl10.9 (4)
 - 7/16" USS washer (6)
 - M12-1.75 nylock nut (4)
- #173 – 3/8" Rivet Nut Install Tool (1)**
- 7/16" serrated flange hex nut (1)
 - 3/8" MIL spec flat washer (2)
 - 3/8"-16 x 1-1/4" hex bolt, gr8 (1)



Before you begin:

- Read all safety warnings.
- Read and understand installation instructions.
- A custom exhaust will be required.
- Modifications to your emergency brake system will be required. You will need to source your own parts for this.
- This kit requires a 4 to 8" suspension lift kit.
- Maximum rear shock length (extended) is 29.5" center to center with 17" coil springs (our 8" coils). Shorter coil springs will require shorter shocks.
- Check all steering/suspension components for wear, replace if needed.
- Contact Iron Rock Off Road with any questions before, during, or after installation.
- Ensure that all parts are present and in good condition using the included parts checklist.**
- Be sure you have the following tools and supplies:

- Floor jack and jack stands
- Basic hand tools
- Multi-purpose grease
- Slope gauge or angle finder.
- Hand drill with good quality 7/16" & 17/32" drill bits
- Anti-seize compound for bolts.
- Welder (for welding brackets to axle)
- Brake line bender
- Double flaring tool (for brake lines)
- If equipped with rear uniframe stiffeners: 5/16" drill bit, 3/8"-16 hand tap, tap holder and cutting oil. You will not need the 17/32" drill bit.



Prepare the parts for installation:

1. Locate four control arms, male ends, and hardware kits (65, 127, 168).
2. Build lower control arms using angled male ends and hardware kits 127: Assemble flex ends per attached instructions (2-5/8").
3. Build upper control arms using 2-3/8" flex end male end and hardware kits 168: Assemble flex ends per attached instructions (2-3/8").
4. Apply anti-seize to male threads and thread into the control arms. Larger male ends go into the larger (lower) control arms.
5. Adjust upper arms to 35-1/2" center to center as a starting point.
6. Adjust lower arms to 43" center to center on the short side to start.
7. Install clamping bolts. Do not tighten at this time.
8. With vehicle on level ground, measure pinion angle. Record angle here _____.



Disassembly:

9. Lift rear of vehicle and support with tall jack stands under the unibody frame.
- **Tip: break lug nuts loose before lifting vehicle. **
10. Ensure that the vehicle is safely supported.
11. Remove the rear tires.
12. Remove catalytic converter, muffler and tailpipe.
13. Remove rear shocks.
14. Remove rear axle.
15. Remove rear leaf springs and shackles.
16. Remove rear bump stops.
17. Remove rear sway bar if equipped.
18. Remove emergency brake cables and junction box.

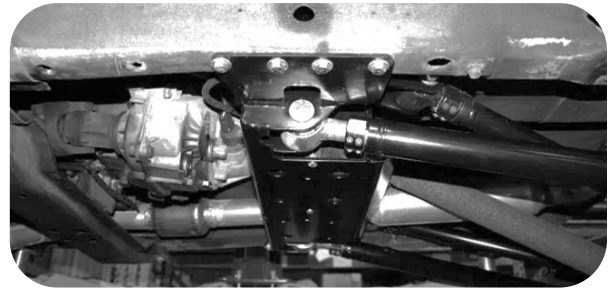

Rear Crossmember:

19. Locate crossmember and hardware kit #174.
20. With the control arm mounts facing the rear, position the crossmember so that the front bolt hole is 12" back from the rear bolt for the factory front crossmember.
21. Center crossmember side to side.
22. Using the crossmember as a template, drill all (8) 7/16" holes.
23. Drill a 1" hole in the side of the uniframe centered between the 7/16" holes. Insert nut plates into frame and secure with 7/16" bolts (4 holes per side)
24. Torque all bolts to 65 ft-lbs.



Rear Spring/Shock Crossmember

25. Place a floor jack underneath the fuel tank for support (do not lift).
26. Remove hanger bolt from passenger side fuel tank strap.
27. Locate spring/shock crossmember and hardware kit 167.
28. Position crossmember as shown, aligning bottom holes in crossmember with bump stop holes in uniframe.
29. Center crossmember side to side.
30. Using the crossmember as a template drill the following in the side of the uniframe: *If **not** equipped with rear uniframe stiffeners, drill (8) 17/32" holes for rivet nuts (see rivet nut installation instructions)
**If equipped with rear uniframe stiffeners, drill (8) 5/16" holes and tap with 3/8"-16 hand tap. **

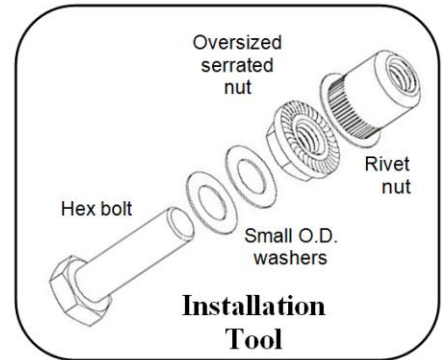

Rivet Nut Installation:

31. Slide the two small O.D. washers and oversized nut onto the bolt. As shown in diagram.
32. Thread bolt with nut and two washers into the rivet nut.
33. Insert assembly into drilled hole.
34. Using a wrench to hold the nut, push inward to prevent the rivet nut from spinning.
35. Tighten the bolt until the rivet nut fully collapses and locks into the hole.
36. Be careful not to strip the threads.
37. Remove bolt and check to make sure insert does not spin when bolt is tightened.

Prepare the Axle Assembly:

38. Cut off any brackets attached to the axle tubes. A plasma cutter, oxy/acetylene torch, or angle grinder with a cut off wheel can be used. Be careful not to cut into the axle tubes.
39. Using an angle grinder, remove any remaining bracketry. Be careful not to grind away any axle tube material.

Measure:

40. Measure the width of the axle and place a mark on the top of the differential at the center of the **axle assembly** – (not differential)

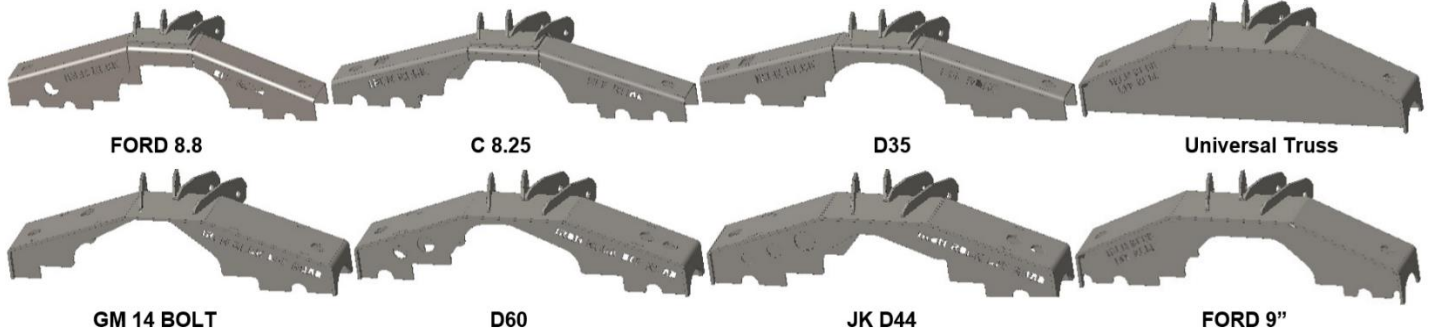

D35, C 8.25 and Ford 8.8 Trusses:

41. (**D35 & C 8.25 Only**) Apply medium strength thread locker to original brake line T-Block bolt and install T-Block Eliminator (#184) where the original brake line T-block was located on the axle tube.
42. Slide the internal gusset into the truss and test fit truss assembly to axle. The alignment hole should match the axle centerline and the internal gusset should rest on the axle tubes outside of the cast center section. Stich weld the gusset into the truss.
43. Fully weld the vertical slots in the truss (near the center). Tack weld the ends of the slots first to avoid warpage. Grind the front sides flush as needed to clear the Upper Control Arm (UCA) base plate.
44. With the truss cool, paint the inside of the truss including above and below the gusset to prevent rust.
45. Tack weld truss to the axle with the face of the truss parallel to rear diff cover mounting surface and the gusset resting on the axle tubes.
- ***When tack welding, ensure your tack welds are strong enough for a test fit, but easy to cut apart if necessary.
46. Tack weld upper control arm mount to truss with front hole aligned with hole in truss.
47. Tack weld upper control arm mount tabs to base plate with shorter tabs in the center.
48. Weld truss to axle and weld upper control arm mounts to truss.
- ***To avoid warping, avoid excessive heat buildup. Weld in short time increments in one

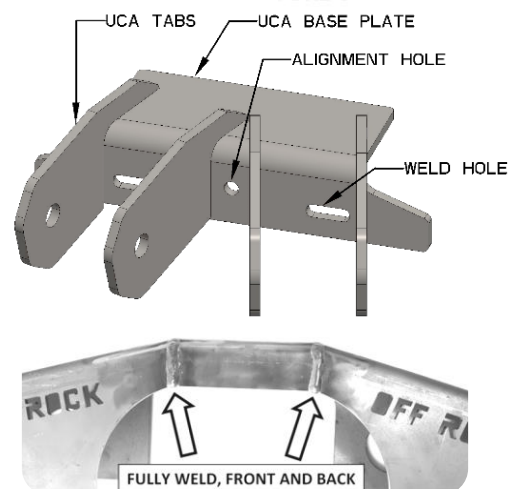

area then move to another part of the axle. Allow time to cool between welds in the same spot.

49. Weld all the way around UCA mounting tabs and UCA base plate.

GM 14 Bolt, D60, JK D44, Sterling 10.5, Ford 9" and Universal Blank Trusses:

50. Tack weld vertical truss plates to truss top plate. Vertical plates are inset 3/8" from outer edge of top plate. Test fit truss assembly to the axle. Ensure vertical plates contact axle tubes.

51. Tack weld truss to the axle with the face of the truss parallel to rear diff cover mounting surface and the top plate resting on the axle tubes.

*****When tack welding, ensure your tack welds are strong enough for a test fit, but easy to cut apart if necessary.**

52. Tack weld upper control arm mount tabs to truss with shorter tabs in the center. See diagram.

53. Fully weld truss assembly, weld truss to axle and weld upper control arm mounts to truss.

*****To avoid warping, avoid excessive heat buildup. Weld in short time increments in one area then move to another part of the axle. Allow time to cool between welds in the same spot.**

54. Weld all the way around UCA mounting tabs.

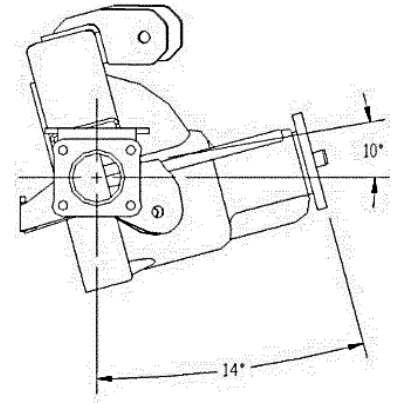
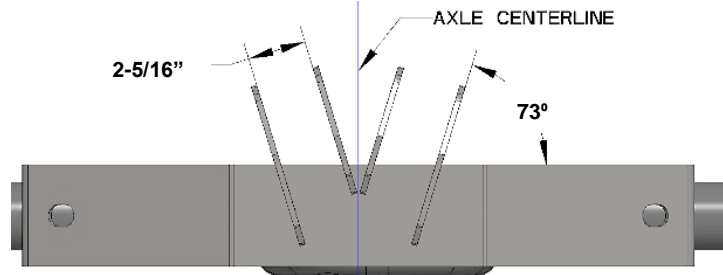

Install Axle Brackets:

55. Mark the location of each bracket on the axle. See drawings.

56. Support the axle assembly on jack stands. Set the pinion angle to 14°. This setting works well for lifts ranging from 4-8", with typical driveshaft combinations.

57. Tack weld lower control arm mounts to the axle with the top surface at a 10° upward angle. Note left and right bracket.

58. Tack weld shock mounts in place with mounting surface exactly vertical.

59. Tack weld spring pads to axle with top surface exactly horizontal.

60. Test in vehicle at ride height to verify pinion angle is ideal and make any necessary changes.

61. Fully weld each bracket to the axle tubes.

*****Tip:** If desired, the spring pads need not be fully welded to the axle tubes. About 1" of weld on each corner is sufficient. This allows you to easily change the spring pad angle if needed for suspension upgrades or installation of a transfer case slip yoke eliminator.

*****Tip:** to avoid warping, avoid excessive heat buildup. Weld in short time increments in one area then move to another part of the axle. Allow time to cool between welds in the same spot.

62. Prep and paint

63. Mount rear brake hose T-fitting to the front side of the truss.

64. Double flare and run new hard lines from brake T-fitting to wheel cylinders.

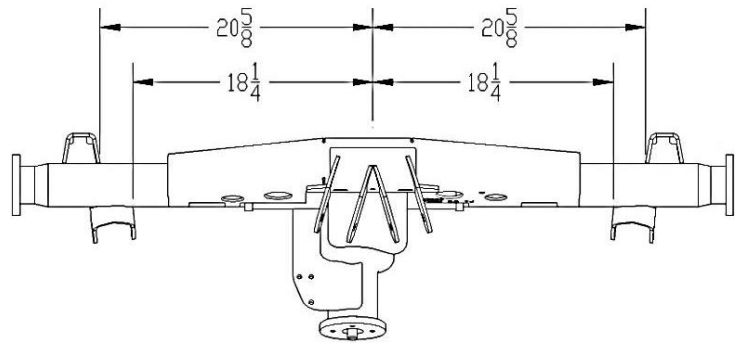

Rear Suspension:

65. Install upper control arms with bend hanging down to clear the floor pan (adjustable threaded end at frame). Use M14 x 95 bolts, nuts, and washers (from hardware kit 171).

66. Install lower control arms. Adjustable threaded end at frame. *Angled male ends to be angled towards the outside of the vehicle when installed. *

*The bends are to be angled upward for ground clearance, and inward to clear the frame. * Use M14 x 100 bolts, nuts, and washers (from hardware kit 171).

67. Install new coil springs, rotate them until they sit as straight as possible (low spot of spring aligned to high side of spring pad). See diagram to the right.

68. Install new shocks.

69. Raise the vehicle and support with jack stands under the rear axle.

70. Bleed brakes at all 4 corners.

71. With full vehicle weight on the suspension, check if the rear axle is centered as desired in the wheel opening. Adjust lower control arms to desired axle position. Adjust upper control arms to desired pinion angle (see step 8).

72. Torque all control arm nuts to 125 ft-lbs.

73. Torque lower control arm clamping bolts to 140 in-lb. Be sure to go back and forth between both bolts several times to ensure even clamping.

74. Install tires and place the vehicle on the ground.

75. Torque lug nuts to spec. (Typical specification is 85-115 ft-lbs., depending on your wheels)

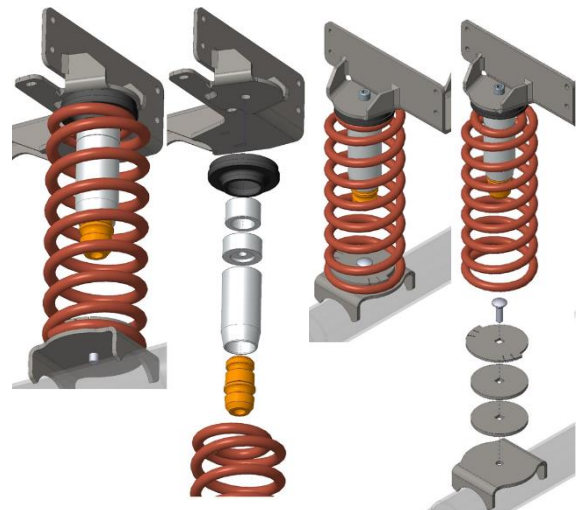
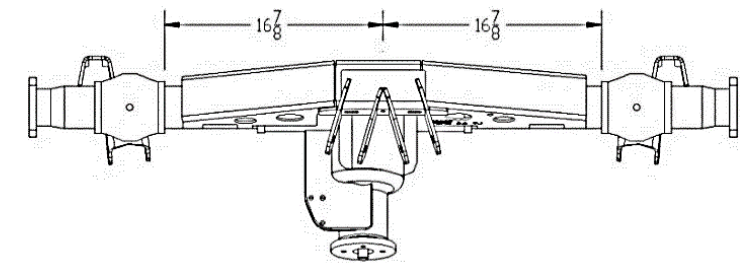

Adjustments and Final Inspection:

76. Check all components for clearance for suspension to fully cycle up and down. Pay special attention to brake lines, axle vent hoses, and ABS wires. Reposition as needed by bending the brackets, relocating, or extending hoses and wiring.

Final Safety Warning:

* Re-torque all fasteners including lug nuts after 100 miles, and frequently inspect all safety critical suspension components. It is the responsibility of the installer to be sure all fasteners are properly tightened after installation and to ensure the owner knows his/her ongoing responsibility. It is the responsibility of the owner of the vehicle to be sure all safety critical components are inspected frequently, especially after off road or other demanding use.

IRON ROCK OFF ROAD

2-5/8" IRO Flex End (6 bolt)

1-877-919-JEEP www.ironrockoffroad.com

Assembly Instructions

Fits All Iron Rock Off Road Long Arm Systems, WJ A-Arms, and Build Your Own Flex End Assemblies.

Parts Checklist:

- Outer housing, weld on (may already be attached to your existing control arm)

#127 - 2-5/8" IRO Flex End (6 bolt)

- 2-5/8" flex end race - 91118 - (2)
- Thrust washer - 91119 - (2)
- 2-5/8" flex end ball - 91117 - (1)
- #10-32 nylock nut - (7)
- #10-32 x 1-3/4" socket head cap screw - (6)
- 90° 1/4"-28 grease zerk fitting - (1)

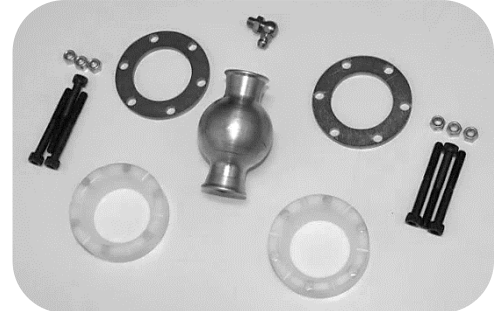

Before you begin:

- Read and understand installation instructions.
- Contact Iron Rock Off Road with any questions before, during, or after installation.
- **Ensure that all parts are present and in good condition per attached shipping checklist!**
- Have these tools handy:
 - 5/32" allen head socket
 - 3/8" open end wrench
 - Inch-lb. torque wrench



Figure 1

Assembly:

1. Insert two #10-32 socket head cap screws into one thrust washer and one plastic race. Spherical bore of race facing away from thrust washer. (Figure 1)
2. Install this small assembly into the flex end housing. The races are a light press fit, use a wide punch and hammer to assist you if needed.
3. Apply a thin coating of multi-purpose grease to the mating surfaces of the ball and both races.
4. Place the ball in the race (inside the flex end). The ball should perfectly fit the contour of the race. (Figure 2)
5. Insert the other race onto the ball so that the spherical bore is contacting the ball. Once again, the races are a light press fit, use a hammer and wide punch if needed. (The two screws should be through one washer and both races at this point)
6. Insert the second thrust washer on top of the flex end housing, sliding the bolts through the holes. (Figure 3)
7. Start nylock nuts on the two bolts that are in the flex end assembly. Hold the nut and turn the bolt.
8. Insert the remaining four cap screws through the remaining holes and install nuts.
9. Snug up all of the bolts fairly tight.
10. Torque bolts evenly, starting at one bolt and continuing using a crisscross pattern. Torque all six bolts to 70 in-lbs., then to 85 in-lbs.
11. Install 90° grease zerk fitting so that it is easily accessed in the vehicle.
12. Grease flex end until grease comes out of the races around the ball.
13. Re-torque bolts to 85 in-lbs. after 5 minutes.

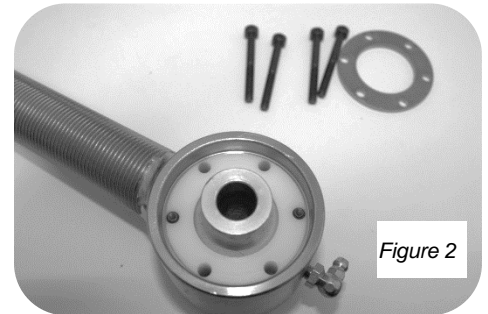

Figure 2

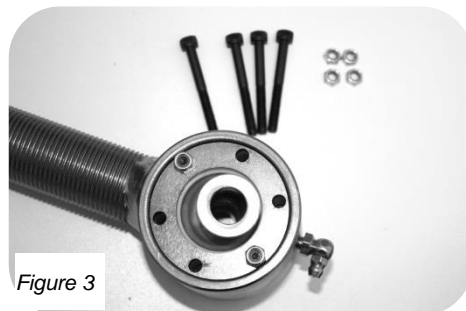

Figure 3

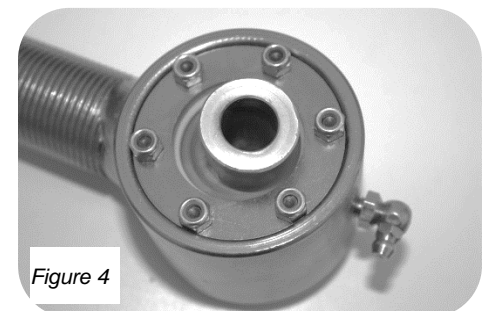

Figure 4

**Reference Only* Complete joint shown fully assembled without housing*

IRON ROCK OFF ROAD

2-3/8" IRO Flex End (8 bolt)
 I-877-919-JEEP www.ironrockoffroad.com Assembly Instructions

Before you begin:

- o Read and understand installation instructions.
- o Contact Iron Rock Off Road with any questions before, during, or after installation.
- o **Ensure that all parts are present and in good condition per attached shipping checklist!**
- o Have these tools handy:
 - o 9/64" Allen head socket
 - o 3/8" open end wrench
 - o Inch-lb. torque wrench
 - o Multipurpose grease/grease gun

Parts Checklist:

- Outer housing, weld on (may already be attached to your existing control arm)

#168 - 2-3/8" IRO Flex End (8 bolt)

- Inner race 91139 (2)
- Thrust washer 91138 (2)
- Ball 91140 (1)
- #8-32 x 1-1/2" socket head cap screw (8)
- 1/4"-28 90° grease zerk fitting (1)
- 1/4"-28 straight grease zerk fitting (1)

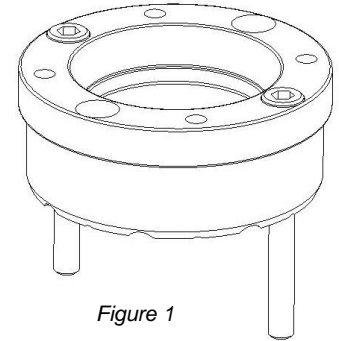
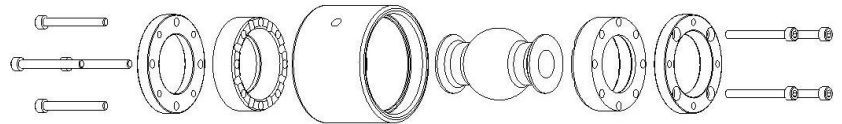
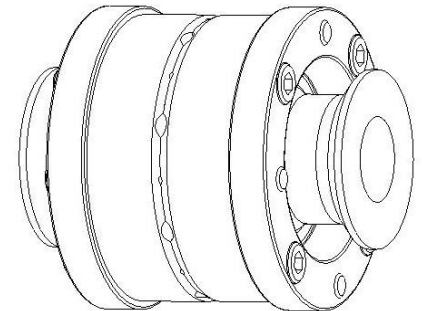

Figure 1

Assembly:

1. Insert two #8-32 socket head cap screws into one thrust washer and one plastic race. Spherical bore of race facing away from thrust washer. (Figure 1)
2. Install this small assembly into the flex end housing. The races are a light press fit, use a wide punch and hammer to assist you if needed.
3. Apply a thin coating of multi-purpose grease to the mating surfaces of the ball and both races.
4. Place the ball in the race (inside the flex end). The ball should perfectly fit the contour of the race.
5. Insert the other race onto the ball so that the spherical bore is contacting the ball. Once again, the races are a light press fit, use a hammer and wide punch if needed. (The two screws should be through one washer and both races at this point)
6. Insert the second thrust washer on top of the flex end housing, aligning the bolts with the threaded holes.
7. Start threading the two bolts into the threaded holes of the thrust washer. Do not fully tighten at this time.
8. Insert the remaining cap screws through the remaining holes and get them started in the threaded washer.
9. Snug up all of the bolts fairly tight. Go back and forth, rechecking each bolt several times to ensure even clamping
10. Torque bolts evenly starting at one bolt using a crisscross pattern, like torqueing lug nuts. Torque all eight bolts to 50 in-lbs., then to 55 in-lbs.
11. Install 90° grease zerk fitting so that it is easily accessed in the vehicle.
12. Use a grease gun to grease the flex end through the zerk fitting. This will be difficult due to the tight tolerances in the flex joint assembly.
13. Re-torque bolts to 55 in-lbs.



**Reference Only* Complete joint shown fully assembled without housing*

