

# IRON ROCK OFF ROAD

## JL 3" Premium Lift Kit Instructions

1-877-919-JEEP www.ironrockoffroad.com

### Parts Checklist:

- 3" Front coil spring 96025 (2)
- 3" Rear coil spring 96005 (96038: 4XE) (2)
- Rear sway bar link 11.25" center to center 92147 (2)
  - #201 - Sway Bar Link Hardware (1)**
    - 12mm sway bar bolt sleeve 92038 (4)
    - 3/4" hourglass bushing 94025 (4)
    - M12 x 65 Hex bolt cl 10.9 (2)
    - M12 Nylock nut (2)
    - 7/16 USS washer (4)
- JL Rear Bump Stop Spacer 2" 80050 (2)
  - #199 - JL Rear Bump Stop Spacer Hardware (1)**
    - 5/16-18 x 3/4 Serrated flange bolt, gr8 (4)
    - 5/16-18 Serrated flange nut (4)
- Stackable/Adjustable Bump Stop Set 13399**
  - 1 Inch Top Bump Stop 88271 (2)
  - 1/2 Inch Bump Stop Spacer 88272 (2)
  - 1 Inch Bump Stop Spacer 88273 (2)
  - 1-1/2 Inch Bump Stop Spacer 88274 (2)
  - #192 - Bump Stop Hardware (1)**
    - 7/16 x 1 1/2" hex bolt, gr5 (2)
    - 7/16 x 2 1/2" hex bolt, gr5 (2)
    - 7/16 x 3 1/2" hex bolt, gr5 (2)
    - 7/16 x 4 1/2" hex bolt, gr5 (2)
    - 7/16 flag nut 80063 (2)



- JL 0-8" front track bar 77016 (1)
- Track bar threaded male end, Flex Joint 77128 (1)



- #306 - JL/JT Track Bar Flex Joint - Male End (1)**
  - Inner race (plastic) 91113 (2)
  - Washer (steel) 77127 (2)
  - Ball 91142 - M14 bolt (1)
  - #5-40 x 1-1/8" Socket head cap screw (9)
  - 3/32" Hex L key, high torque (hex plus) (1)

### Standard Track Bar

- #235 - Front Track Bar Hardware (1)**
  - Track bar bushing half 80014 (2)
  - Track bar bushing sleeve 80003 (1)
  - Track Bar clamp 95044 (1)
  - 5/16-18 x 2 carriage bolt gr5 (1)
  - 5/16-18 hex flange nut (1)

### -Optional Premium Track Bar Upgrade-

- #254 - Track Bar Flex End Hardware - 14mm (1)**
  - Inner race (plastic) 91113 (2)
  - End cap (steel) 91112 (2)
  - Ball 91142 - M14 bolt (1)
  - #5-40 x 1 1/4" Socket head cap screw (9)
  - 3/32" Hex L key, high torque (hex plus) (1)
- #281 - Track Bar Clamp Hardware (1)**
  - Track Bar clamp 95044 (1)
  - 5/16-18 x 2 carriage bolt gr5 (1)
  - 5/16-18 hex flange nut (1)

- JL 0-8" rear track bar 77000 (1)



### Standard Track Bar

- Track bar threaded male end 92004 (1)

- #236 - Rear Track Bar Hardware (1)**
  - Track bar bushing half 80014 (4)
  - Track bar bushing sleeve 80003 (2)
  - Track Bar clamp 95044 (1)
  - 5/16-18 x 2 carriage bolt gr5 (1)
  - 5/16-18 hex flange nut (1)

### -Optional Premium Track Bar Upgrade-

- Track bar threaded male end, Flex Joint 77128 (1)
- #254 - Track Bar Flex End Hardware - 14mm (1)**
  - Inner race (plastic) 91113 (2)
  - End cap (steel) 91112 (2)
  - Ball 91142 - M14 bolt (1)
  - #5-40 x 1 1/4" Socket head cap screw (9)
  - 3/32" Hex L key, high torque (hex plus) (1)
- #306 - JL/JT Track Bar Flex Joint - Male End (1)**
  - Inner race (plastic) 91113 (2)
  - Washer (steel) 77127 (2)
  - Ball 91142 - M14 bolt (1)
  - #5-40 x 1-1/8" Socket head cap screw (9)
  - 3/32" Hex L key, high torque (hex plus) (1)
- #281 - Track Bar Clamp Hardware (1)**
  - Track Bar clamp 95044 (1)
  - 5/16-18 x 2 carriage bolt gr5 (1)
  - 5/16-18 hex flange nut (1)

### -Standard Front Sway Bar Links-

- Front sway bar link 8.75" center to center 92145 (2)
- #201 - Sway Bar Link Hardware (1)**
  - 12mm sway bar bolt sleeve 92038 (4)
  - 3/4" hourglass bushing 94025 (4)
  - M12 x 65 Hex bolt cl 10.9 (2)
  - M12 Nylock nut (2)
  - 7/16 USS washer (4)



### -Optional Front Sway Bar Disconnect Upgrade-

- Front Sway Bar Link, 7.5" center to center 92246 (2)
- Passenger Side Disconnect Bracket 77080 (1)
- Passenger Side Disconnect Plate 77082 (1)
- Driver Side Disconnect Plate Small 77084 (1)
- Driver Side Disconnect Plate Large 77083(1)

- #268 - Sway Bar Disconnect Bushings (1)**
  - Poly Bushing 94025 (4)

- #276 - JL Sway Bar Disco. Hardware (1)**

- Disconnect Pin 94028 (4)
- 1/2-20 x 1" Hex Bolt, gr8 (4)
- 1/2 F436 Hard Washer (8)
- 1/4" x 1-1/4" Spring Pin (4)
- M12 x 70 Hex Bolt (1)
- M12 x 45 Hex Bolt (1)
- M12 Nylock Nut (2)



- JL LCA Front 77064B (2) **16mm Bushing Installed**

- #65 - Adjustable LCA Clamping Hardware (1)**
  - 1/4"-28 x 1-1/8" socket head cap screw (4)
  - 1/4"-28 hex nut, gr8 (4)



- Standard - LCA Rubber Bushing Male End, Straight 99070B (2)
- Optional - LCA Flex Joint Male End, Straight 92186 (2)

- #233 - 2 5/8" 6 Bolt 16mm Flex End Hardware (2)**
  - Inner race 91118 (2)
  - Thrust washer 91119 (2)
  - 2-5/8" Flex End Ball 16mm 91242 (1)
  - 10-32 x 1-3/4" Socket Head Cap Screw (6)
  - 10-32 Nylock Nut (6)
  - 1/4"-28 90° Grease zerk Fitting (1)

JL LCA Rear 80010B (2) **14mm Bushing Installed**



- #65 - Adjustable LCA Clamping Hardware (1)**
  - 1/4"-28 x 1-1/8" socket head cap screw (4)
  - 1/4"-28 hex nut, gr8 (4)

**Standard** - LCA Rubber Bushing Male End, Straight 99070B (2)

**Optional** - LCA Flex Joint Male End, Straight 92186 (2)

- #127 - 2 5/8" 6 Bolt IRO Flex End Hardware (2)**
  - Inner race 91118 (2)
  - Thrust washer 91119 (2)
  - 2-5/8" Flex End Ball 91117 (1)
  - 10-32 x 1-3/4" Socket Head Cap Screw (6)
  - 10-32 Nylock Nut (6)
  - 1/4"-28 90° Grease zerk Fitting (1)

**Standard** - JL Rear UCA w/ Rubber Bushing 80196B (2)

UCA Rear Male End 80023B (2)



- #186 - UCA Clamping Hardware 13312 (1)**
  - 3/8-16 X 1-1/4 Hex bolt gr8 (2)
  - 3/8-16 Nylock flange nut gr8 (2)
  - 3/8 Mil spec washer (2)

**-Optional Flex Joint Upgrade-**

**Optional** - JL Rear UCA w/ Flex Joint 80022 (2)

UCA Rear Male End 80023 (2)



- #186 - UCA Clamping Hardware 13312 (1)**
  - 3/8-16 X 1-1/4 Hex bolt gr8 (2)
  - 3/8-16 Nylock flange nut gr8 (2)
  - 3/8 Mil spec washer (2)
- #168 - 2 3/8" 8 Bolt IRO Flex End Hardware (2)**
  - Inner race 91139 (2)
  - Thrust washer 91138 (2)
  - 2-3/8" Flex End Ball 91140 (1)
  - 8-32 x 1-1/2" Socket Head Cap Screw (8)
  - 90 Degree 1/4"-28 Grease Zerk Fitting (1)

**Standard** - JL Front UCA w/ Rubber Bushing 77072B (2)

UCA Front Male End 80025 (2)



- #186 - UCA Clamping Hardware 13312 (1)**
  - 3/8-16 X 1-1/4 Hex bolt gr8 (2)
  - 3/8-16 Nylock flange nut gr8 (2)
  - 3/8 Mil spec washer (2)

**-Optional Flex Joint Upgrade-**

**Optional** - JL Front UCA w/ Flex Joint 77067 (2)

UCA Front Male End 80025 (2)



**#186 - UCA Clamping Hardware 13312 (1)**

- 3/8-16 X 1-1/4 Hex bolt gr8 (2)
- 3/8-16 Nylock flange nut gr8 (2)
- 3/8 Mil spec washer (2)

**#185 - UCA Front 2" Flex End Hardware 13311 (2)**

- End Cap 91124 (2)
- Race 91123 (2)
- 12mm Ball 91122 (1)
- 5-40 X 1-1/4 SHCS (9)
- 3/32 Hex L-key (hex plus) (1)
- 1/4-28 Straight grease zerk (1)

## Shocks

**Trail Tamer HD Hydro (Standard)**

- Front shock 79004 (2)
- Rear shock 79005 (2)

**#232 - JL Shock Hardware (1)**

- Upper shock sleeve 79012 (4)
- Upper shock mount spacer 79013 (8)
- M12 x 70 Hex bolt cl 10.9 (2)
- M12 Nylock nut (2)
- 7/16 USS washer (4)

**Doetsch Upgrade (Optional)**

- Front shock DT 8299 (2)
- Rear shock DT 8371 (2)

**#232 - JL Shock Hardware (1)**

- Upper shock sleeve 79012 (4)
- Upper shock mount spacer 79013 (8)
- M12 x 70 Hex bolt cl 10.9 (2)
- M12 Nylock nut (2)
- 7/16 USS washer (4)

**Bilstein Upgrade (Optional)**

- Front shock 33-185552 (2)
- Rear shock 33-104652 (2)

**#231 - JL Bilstein Shock Hardware (1)**

- 12mm X 1.49" Shock Sleeve 79008 (4)

**#232 - JL Shock Hardware (1)**

- Upper shock sleeve 79012 (4)
- Upper shock mount spacer 79013 (8)
- M12 x 70 Hex bolt cl 10.9 (2)
- M12 Nylock nut (2)
- 7/16 USS washer (4)



## **Before you begin:**

- \*\*\*Ensure that all parts are present and in good condition using above shipping checklist. \*\*\*
- Read and understand all installation instructions.
- Tools required:
  - Floor jack and jack stands.
  - Basic hand tools
  - Torque wrenches capable of 70-85 in.-lb. and 75-130 ft.-lb.
  - Medium thread locker
  - Anti-seize compound.
  - Multipurpose grease
  - 7/16" drill bit and drill

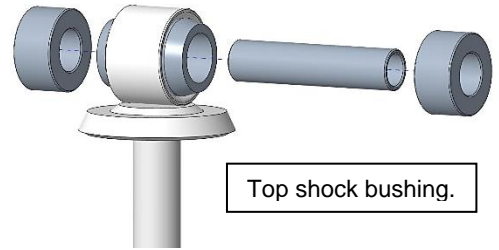

## **Prepare the parts for installation:**

1. **Shocks:** Locate the front and rear shocks and **HK #232**.
2. Grease and install the long sleeve into the top bushing of the front and rear shocks. The long sleeve should be approximately in the center of the bushing.
3. Grease and install the short shock sleeves (included with shocks) into the bottom bushing.
4. **Track Bars:** Locate front track bar, track bar **HK #235**, **HK #306**, and track bar threaded male end.
5. If you purchased the **Premium Track Bar Upgrade** refer to the track bar flex joint assembly instructions at the end of this document.
6. Locate rear track bar, track bar **HK #236** and track bar threaded male end.
7. Lubricate track bar bushings and bushing sleeves with multi-purpose grease and install into track bars.
8. Slip clamping bracket onto adjusting end of track bar with the opening up and insert the 5/16 carriage bolt from rear and nut facing forward.
9. Apply anti-seize and thread the track bar male end into the track bar and adjust to length listed in the chart as a starting point.
10. Tighten the clamping bracket.



11. **Control Arms:** Use a light coat of anti-seize and thread the male ends into the control arms and adjust to the lengths listed in the chart as a starting point.
12. If you upgraded to flex joints refer to the flex joint assembly instructions at the end of this document.
13. assemble the flex ends into the threaded male ends.
14. Install 1/4" clamping bolts (**HK #65**) in the lower control arms, do not tighten at this time.
15. Install 3/8" bolts (**HK #186**) in the upper control arms, do not tighten at this time.
16. **Sway Bar Links:** Grease and install the hourglass bushings into the links. **HK #201**
17. Grease and install the sway bar link bolt sleeves into the bushings. All sleeves are the same (12mm I.D.). If you purchased the **IRO Sway Bar Disconnect Upgrade** refer to the assembly instructions at the end of this document.



## **Front installation:**

18. Lift front of vehicle and support with jack stands under frame rails.  
\*\*Tip: break lug nuts loose before lifting vehicle.
19. Remove front wheels.
20. Disconnect front sway bar links.
21. Support front axle with jack stands and remove shocks.
22. Remove front track bar.
23. Remove factory lower control arms.
24. Remove coil springs.
25. Determine your desired bump stop height. IRO recommends 3" as a starting point.  
\*Bump stop height is determined by many variables: tire size, wheel offset, fender clearance, fender trimming.
26. Stack bump stop top and spacers to achieve desired height and align them with the correct bolt length. **HK #192**
27. Drill out the existing hole in the center of your lower spring mount with a 7/16 drill bit.
28. Position the flag nut under the mount, aligning the nut with the drilled hole. You may have to bend the flag nut slightly.
29. Apply a small amount of medium strength thread locker to bump stop bolt and install into flag nut.
30. Ensure the bolt hex engages the hex in the top bump stop.
31. Spin the bump stop stack until tight. An oil filter wrench works well for this. Do not over-tighten, let the threadlocker do most of the work.  
\*\*To maximize your suspension flex: Reconnect the shocks to the axle and temporarily install tires.

Track Bar & Control Arm Length (Center to Center)	
Front UCA (Upper Control Arm)	20-1/4"
Front LCA (Lower Control Arm)	24-1/4"
Rear UCA	17-3/8"
Rear LCA	20"
Front Track Bar	33-7/8"
Rear Track Bar	37-3/4"

Bump Stop Height	Bolt Length
4.0 Inch	4.5"
3.5 Inch	
3.0 Inch	3.5"
2.5 Inch	
2.0 Inch	2.5"
1.5 Inch	
1.0 Inch	1.5"

- With the shocks connected and springs out use a jack to check suspension articulation left and right, as well as both sides fully compressed. Turn the wheels left and right while suspension is articulated.  
\*\*If interference between the tires and body is found adjust bump stop height or trim body work accordingly.
32. Install new lower control arms using the factory hardware. Do not tighten bolts at this time.  
The bend goes up for ground clearance and in for tire clearance. The rubber bushing goes to the axle and the flex end at the frame.
  33. Remove factory upper control arms and install new upper control arms using the factory hardware. Clamping bolt facing down. Do not tighten bolts at this time.
  34. Install new coil springs.

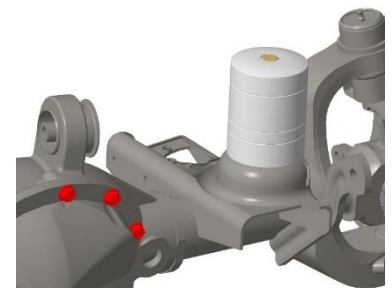

35. Install new shocks with a new M12 x 70 bolt at the bottom. **HK #232**
36. Reinstall front sway bar links.
37. Install new front track bar, threaded end to axle side. The clamp facing up, nut facing front.
38. Reinstall front wheels.

**Rear installation:**

39. Lift rear of vehicle and support with jack stands under frame rails.  
 \*\*Tip: break lug nuts loose before lifting vehicle.
40. Remove rear wheels.
41. Remove sway bar links.
42. Support the rear axle with jack stands and remove shocks.
43. Remove track bar.
44. Remove coil springs.
45. Remove factory lower control arms and install new lower control arms using the factory hardware. Clamping bolts facing down, flex end at the frame, grease zerks pointed down.
46. Remove factory upper control arms and install new upper control arms using the factory hardware. Clamping bolt facing in, flex end at the frame.  
 \*For ease of installation: it is recommended that the rear axle be set at ride height and the upper control arm bolts be torqued before install of the rear bump stop spacers.
47. Install rear bump stop spacers using **HK #199**. The slant should point forward.
48. Install new springs.
49. Install new shocks.
50. Install new track bar.
51. Install new sway bar links.
52. Reinstall rear wheels.
53. Lower vehicle onto ground.

**Final Torque and Adjustments:**

54. The draglink **must** be adjusted to center the steering wheel before driving the vehicle. Failure to do so will cause an error with the factory traction control system and will result in odd handling and decreased performance.
55. Check that axles are centered side to side and adjust track bars as needed.
56. With the vehicle weight on the suspension, tighten front lower control arm bolts to 130 lb-ft.  
 Tighten front upper control arm bolts to 75 lb-ft.
57. Tighten rear upper and lower control arm bolts to 130 lb-ft.
58. Torque lug nuts to factory spec. (85 to 115 ft-lbs)
59. Ensure flex ends are parallel with control arm mounts then torque lower control arm clamping bolts to 140 in-lb. Be sure to go back and forth between both bolts several times to ensure even clamping.
60. Check all components for clearance for suspension to fully cycle up and down and wheels to turn lock to lock. Pay special attention to brake lines, axle vent hoses, and ABS wires. Reposition as needed by bending the brackets, relocating, or extending hoses and wiring.

**Final Safety Warning:**

\* Re-torque all fasteners after 100 miles, and frequently inspect all safety critical suspension components. It is the responsibility of the installer to be sure all fasteners are properly tightened after installation and to ensure the owner knows his/her ongoing responsibility. It is the responsibility of the owner of the vehicle to be sure all safety critical components are inspected frequently, especially after off road or other demanding use.

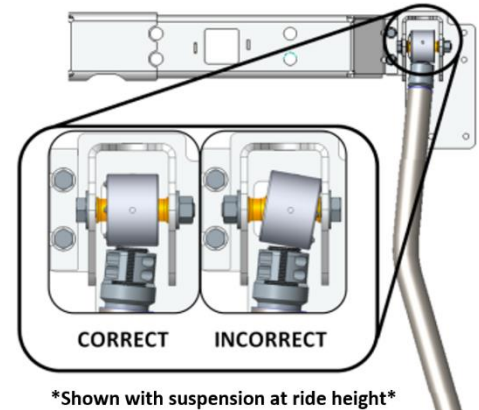

# IRON ROCK OFF ROAD

2-5/8" IRO Flex End 16mm Bolt Assembly Instructions

1-877-919-JEEP www.ironrockoffroad.com

**\*\*\*NOTE: This flex end is ONLY for the front lower control arm of the Jeep Wrangler JL and Jeep Gladiator JT. This flex end uses a larger 16mm through bolt. Do not confuse it with HK #127**

## **Before you begin:**

- o Read and understand installation instructions.
- o Contact Iron Rock Off Road with any questions before, during, or after installation.
- o **Ensure that all parts are present and in good condition per attached shipping checklist!**
- o Have these tools handy:
  - o 5/32" Allen head socket
  - o 3/8" open end wrench
  - o Inch-lb. torque wrench
  - o Multipurpose grease/grease gun



## **Parts Checklist:**

- Outer housing, weld on (may already be attached to your existing control arm)

### **#233 - 2-5/8" IRO Flex End (6 bolt)**

- 2-5/8" flex end race 91118 (2)
- Thrust washer 91119 (2)
- 2-5/8" flex end ball 16mm 91242 (1)
- #10-32 nylock nut (7)
- #10-32 x 1-3/4" socket head cap screw (6)
- 90° 1/4"-28 grease zerk fitting (1)



Figure 1

## **Assembly:**

1. Insert two #10-32 socket head cap screws into one thrust washer and one plastic race. Spherical bore of race facing away from thrust washer. (Figure 1)
2. Install this small assembly into the flex end housing. The races are a light press fit, use a wide punch and hammer to assist you if needed.
3. Apply a thin coating of multi-purpose grease to the mating surfaces of the ball and both races.
4. Place the ball in the race (inside the flex end). The ball should perfectly fit the contour of the race. (Figure 2)
5. Insert the other race onto the ball so that the spherical bore is contacting the ball. Once again, the races are a light press fit, use a hammer and wide punch if needed. (The two screws should be through one washer and both races at this point)
6. Insert the second thrust washer on top of the flex end housing, sliding the bolts through the holes. (Figure 3)
7. Start nylock nuts on the two bolts that are in the flex end assembly. Hold the nut and turn the bolt.
8. Insert the remaining four cap screws through the remaining holes and install nuts. (Figure 4)
9. Snug up all of the bolts fairly tight.
10. Torque bolts evenly, starting at one bolt and continuing using a crisscross pattern. Torque all six bolts to 70 in-lbs., then to 85 in-lbs.
11. Install 90° grease zerk fitting so that it is easily accessed in the vehicle.
12. Grease flex end until grease comes out of the races around the ball.
13. Re-torque bolts to 85 in-lbs. after 5 minutes.

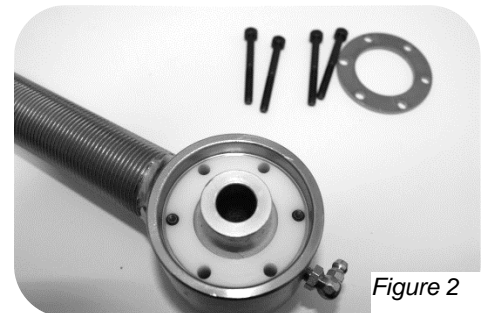

Figure 2

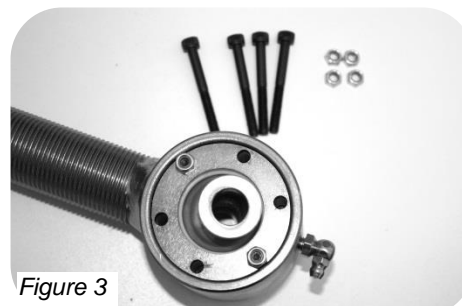

Figure 3

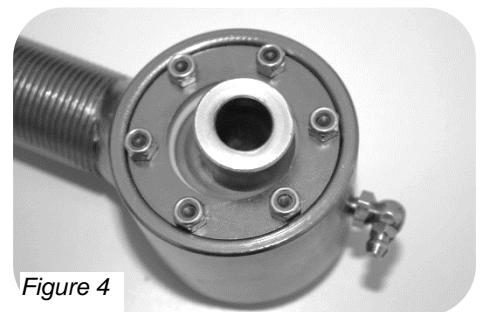

Figure 4

*\*Reference Only\* Complete joint shown fully assembled without housing*

# IRON ROCK OFF ROAD

2-5/8" IRO Flex End (6 bolt)  
Assembly Instructions

1-877-919-JEEP www.ironrockoffroad.com

*Fits All Iron Rock Off Road Long Arm Systems, WJ A-Arms, and Build Your Own Flex End Assemblies.*

**Before you begin:**

- o Read and understand installation instructions.
- o Contact Iron Rock Off Road with any questions before, during, or after installation.
- o **Ensure that all parts are present and in good condition per attached shipping checklist!**
- o Have these tools handy:
  - o 5/32" Allen head socket
  - o 3/8" open end wrench
  - o Inch-lb. torque wrench
  - o Multipurpose grease/grease gun

**Parts Checklist:**

- Outer housing, weld on (may already be attached to your existing control arm)

**#127 - 2-5/8" IRO Flex End (6 bolt)**

- 2-5/8" flex end race 91118 (2)
- Thrust washer 91119 (2)
- 2-5/8" flex end ball 91117 (1)
- #10-32 nylock nut (7)
- #10-32 x 1-3/4" socket head cap screw (6)
- 90° 1/4"-28 grease zerker fitting (1)

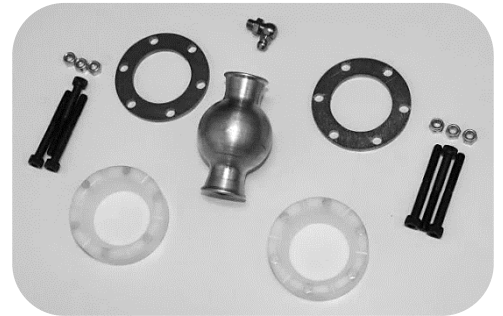

Figure 1

**Assembly:**

14. Insert two #10-32 socket head cap screws into one thrust washer and one plastic race. Spherical bore of race facing away from thrust washer. (Figure 1)
15. Install this small assembly into the flex end housing. The races are a light press fit, use a wide punch and hammer to assist you if needed.
16. Apply a thin coating of multi-purpose grease to the mating surfaces of the ball and both races.
17. Place the ball in the race (inside the flex end). The ball should perfectly fit the contour of the race. (Figure 2)
18. Insert the other race onto the ball so that the spherical bore is contacting the ball. Once again, the races are a light press fit, use a hammer and wide punch if needed. (The two screws should be through one washer and both races at this point)
19. Insert the second thrust washer on top of the flex end housing, sliding the bolts through the holes. (Figure 3)
20. Start nylock nuts on the two bolts that are in the flex end assembly. Hold the nut and turn the bolt.
21. Insert the remaining four cap screws through the remaining holes and install nuts. (Figure 4)
22. Snug up all of the bolts fairly tight.
23. Torque bolts evenly, starting at one bolt and continuing using a crisscross pattern. Torque all six bolts to 70 in-lbs., then to 85 in-lbs.
24. Install 90° grease zerker fitting so that it is easily accessed in the vehicle.
25. Grease flex end until grease comes out of the races around the ball.
26. Re-torque bolts to 85 in-lbs. after 5 minutes.

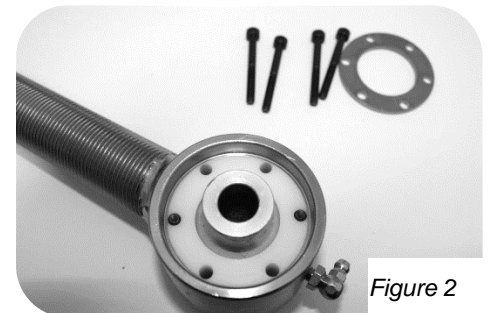

Figure 2

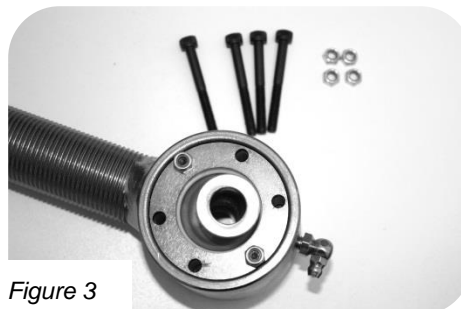

Figure 3

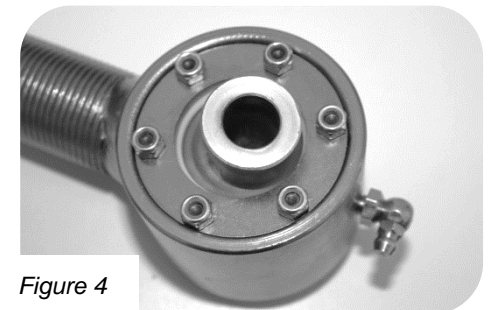

Figure 4

*\*Reference Only\* Complete joint shown fully assembled without housing*

# IRON ROCK OFF ROAD

2-3/8" IRO Flex End (8 bolt)  
**Assembly Instructions**  
 I-877-919-JEEP www.ironrockoffroad.com

**Before you begin:**

- o Read and understand installation instructions.
- o Contact Iron Rock Off Road with any questions before, during, or after installation.
- o **Ensure that all parts are present and in good condition per attached shipping checklist!**
- o Have these tools handy:
  - o 9/64" Allen head socket
  - o 3/8" open end wrench
  - o Inch-lb. torque wrench
  - o Multipurpose grease/grease gun

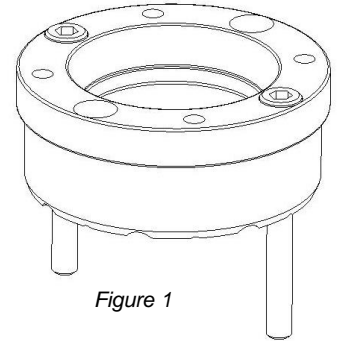

Figure 1

**Parts Checklist:**

- Outer housing, weld on (may already be attached to your existing control arm)

**#168 - 2-3/8" IRO Flex End (8 bolt)**

- Inner race 91139 (2)
- Thrust washer 91138 (2)
- Ball 91140 (1)
- #8-32 x 1-1/2" socket head cap screw (8)
- 1/4"-28 90° grease zerk fitting (1)
- 1/4"-28 straight grease zerk fitting (1)

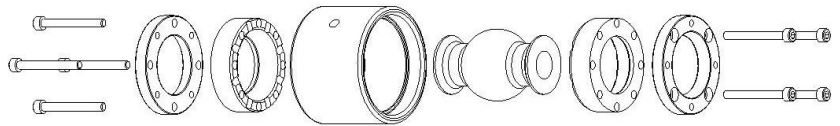

**Assembly:**

1. Insert two #8-32 socket head cap screws into one thrust washer and one plastic race. Spherical bore of race facing away from thrust washer. (Figure 1)
2. Install this small assembly into the flex end housing. The races are a light press fit, use a wide punch and hammer to assist you if needed.
3. Apply a thin coating of multi-purpose grease to the mating surfaces of the ball and both races.
4. Place the ball in the race (inside the flex end). The ball should perfectly fit the contour of the race.
5. Insert the other race onto the ball so that the spherical bore is contacting the ball. Once again, the races are a light press fit, use a hammer and wide punch if needed. (The two screws should be through one washer and both races at this point)
6. Insert the second thrust washer on top of the flex end housing, aligning the bolts with the threaded holes.
7. Start threading the two bolts into the threaded holes of the thrust washer. Do not fully tighten at this time.
8. Insert the remaining cap screws through the remaining holes and get them started in the threaded washer.
9. Snug up all of the bolts fairly tight. Go back and forth, rechecking each bolt several times to ensure even clamping.
10. Torque bolts evenly starting at one bolt using a crisscross pattern, like torquing lug nuts. Torque all eight bolts to 50 in-lbs., then to 55 in-lbs.
11. Install 90° grease zerk fitting so that it is easily accessed in the vehicle.
12. Use a grease gun to grease the flex end through the zerk fitting. This will be difficult due to the tight tolerances in the flex joint assembly.
13. Re-torque bolts to 55 in-lbs.

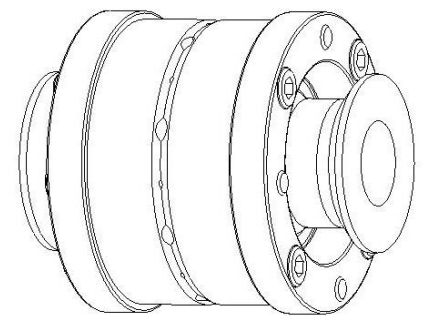

*\*Reference Only\* Complete joint shown fully assembled without housing*

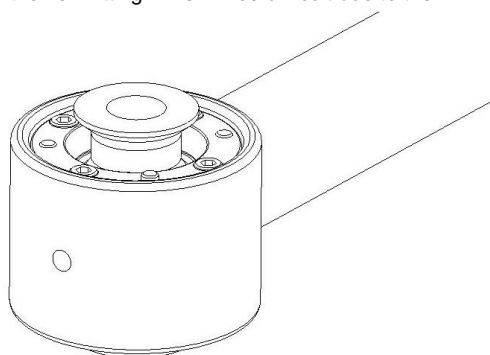

# IRON ROCK OFF ROAD

## 2" IRO Flex End (8 bolt) Assembly Instructions

1-877-919-JEEP www.ironrockoffroad.com

*Fits All Iron Rock Off Road Long Arm Systems and Build Your Own Flex End Assemblies.*

### Parts Checklist:

- Optional: 10676** **#140 – 2" Flex Joint 8-Bolt 10mm Weld-on (1)**
  - End cap 91124 (2)
  - Race 91123 (2)
  - 5-40 x 1-1/4" socket head cap screw (9)
  - 3/32" Hex L key, high torque (hex plus) (1)
  - 2" flex end ball 10mm, 8 bolt, 91121 (1)
  - Outer housing, weld on (may already be attached to your existing control arm)
  
- Optional: 10677** **#141 – 2" Flex Joint 8-Bolt 10mm Press In (1)**
  - End cap 91124 (2)
  - Race 91123 (2)
  - 5-40 x 1-1/4" socket head cap screw (9)
  - 3/32" Hex L key, high torque (hex plus) (1)
  - 2" flex end ball 10mm, 8 bolt, 91121(1)
  - Outer housing, press in 91078 (1)
  
- Optional: 10678** **#142 – 2" Flex Joint 8-Bolt 12mm Weld-on (1)**
  - End cap 91124 (2)
  - Race 91123 (2)
  - 5-40 x 1-1/4" socket head cap screw (9)
  - 3/32" Hex L key, high torque (hex plus) (1)
  - 2" flex end ball 12mm, 8 bolt, 91122 (1)
  - Outer housing, weld on (may already be attached to your existing control arm)
  
- Optional: 10679** **#143 – 2" Flex Joint 8-Bolt 12mm Press In (1)**
  - End cap 91124 (2)
  - Race 91123 (2)
  - 5-40 x 1-1/4" socket head cap screw (9)
  - 3/32" Hex L key, high torque (hex plus) (1)
  - 2" flex end ball 12mm, 8 bolt, 91122 (1)
  - Outer housing, press in 91078 (1)
  
- Optional: 10680** **#144 – 2" Flex Joint 8-Bolt 1/2" Weld-on (1)**
  - End cap 91124 (2)
  - Race 91123 (2)
  - 5-40 x 1-1/4" socket head cap screw (9)
  - 3/32" Hex L key, high torque (hex plus) (1)
  - 2" flex end ball 1/2", 8 bolt, 91126 (1)
  - Outer housing, weld on (may already be attached to your existing control arm)
  
- Optional: 10681** **#145 – 2" Flex Joint 8-Bolt 1/2" Press In (1)**
  - End cap 91124 (2)
  - Race 91123 (2)
  - 5-40 x 1-1/4" socket head cap screw (9)
  - 3/32" Hex L key, high torque (hex plus) (1)
  - 2" flex end ball 1/2", 8 bolt, 91126 (1)
  - Outer housing, press in 91078 (1)

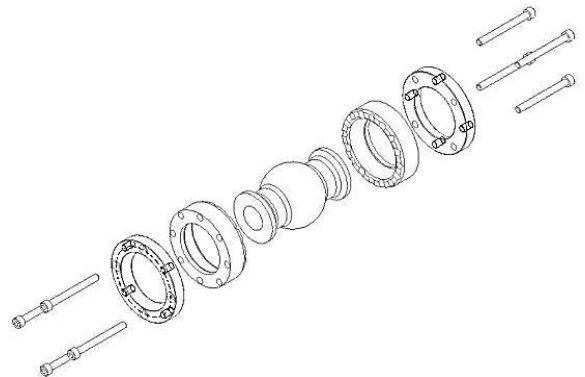



### **Before you begin:**

- Read and understand installation instructions.
- Contact Iron Rock Off Road with any questions before, during, or after installation.
- **Ensure that all parts are present and in good condition per attached shipping checklist!**

### **Assembly:**

1. Install outer tube (weld on or press in).
2. If using the press-in replacement for OEM rubber bushings:
  - a. Remove the existing bushing using a hammer and punch. If necessary, punch the inner sleeve out first, then the rubber, then cut through the metal outer sleeve with a metal cutting blade on a Sawzall, then remove the metal outer shell.
  - b. To install the new press-in outer tube, our installation tool (sold separately) is highly recommended. See installation tool instructions for proper tool use.
  - c. If not using the Iron Rock installation tool, precaution must be taken to avoid damaging the precision machined inner surfaces. Using a bearing race and seal driver press the outer tube into the axle housing or control arm. In order to avoid damage to the precision parts, use the minimum amount of force needed to complete the job. Ensure the tube is fully seated in place. Using a hammer and punch (3/8" diameter punch works well), bend the thin edge on the flex end tube outward to lock it in place. (Use roughly 3/8" wide bends in two places.)
3. Insert two 5-40 socket head cap screws into one end cap and one race. Spherical bore of race facing away from end cap.
4. Install this small assembly into the flex end housing. The races are a tight fit, use a hammer and a wide punch to assist you if needed.
5. Apply a thin coating of multi-purpose grease to the mating surfaces of the ball and both races.
6. Place the ball in the race (inside the flex end). The ball should perfectly fit the contour of the race.
7. Insert the other race onto the ball so that the spherical bore is contacting the ball. Once again, the races are a tight fit, use a hammer and wide punch if needed. (The two screws should be through one washer and both races at this point).
8. Insert the second end cap in the flex end housing, sliding the bolts through the holes.
9. Start threading the two bolts that are in the flex end assembly.
10. Insert the remaining six cap screws through the remaining holes.
11. Snug up all of the bolts fairly tight.
12. Torque bolts evenly starting at one bolt using a crisscross pattern, like torquing lug nuts. Torque all eight bolts to 20 in/lbs.



# IRON ROCK OFF ROAD

## Track Bar Flex End Assembly Instructions

1-877-919-JEEP www.ironrockoffroad.com

### Parts Checklist:

#### #122 - Track Bar Flex End Hardware - 12mm (1)

- Inner race (plastic) 91113 (2)
- End cap (steel) 91112 (2)
- Ball 91104 – M12 bolt (1)
- #5-40 x 1 1/4" Socket head cap screw (9)
- 3/32" Hex L key, high torque (hex plus) (1)

#### #254 - Track Bar Flex End Hardware - 14mm (1)

- Inner race (plastic) 91113 (2)
- End cap (steel) 91112 (2)
- Ball 91142 – M14 bolt (1)
- #5-40 x 1 1/4" Socket head cap screw (9)
- 3/32" Hex L key, high torque (hex plus) (1)



### Safety Warning:

Installation and assembly of this part requires knowledge of steering and suspension systems. Failure to precisely adhere to installation procedure may cause a part failure resulting in vehicle damage and serious injury or death. This part only fits Iron Rock Off Road track bars in good condition. Iron Rock Off Road makes no claims that this part will fit track bars from other manufacturers. Improper fitment may cause a part failure resulting in vehicle damage, serious injury, or death.

### Before you begin:

- o Read and understand installation instructions.
- o Contact Iron Rock Off Road with any questions before, during, or after installation.
- o **Ensure that all parts are present and in good condition per attached shipping checklist!**
- o Ensure that you have high strength threadlocker (such as red Loctite) and multi-purpose grease.

### Fitment:

This kit replaces the poly bushings and inner sleeve in your Iron Rock Off Road track bar. This part only fits track bars manufactured by Iron Rock Off Road after 2009 with an inside diameter of 1.510", a width of 1.250", and a radiused inside corner.

**\*\*\*To verify fitment: Remove the track bar from your vehicle, remove the poly bushings, clean the parts, and verify the following is true: \*\*\***

- The plastic races fit tight inside the inside bore.
- Both end caps fit the inside bore with just a bit of "wobble room".
- Both end caps slide in freely until the flat shoulder rests firmly against the end of the outer tube.
- The overall width of the outer tube is 1.250". This can be measured with a caliper or verified after flex end is fully assembled. Once fully assembled (bolts torqued to spec.) the shoulders of the end caps should rest firmly against the ends of the outer tube. At the same time, the ball should fit tight inside the assembly. It should require a tool (such as a screwdriver) to pivot or rotate the ball. The ball should pivot smoothly with even resistance in any position.



If any of those steps cannot be verified, please contact us to order a new track bar.

Bolt size: This bushing replacement assembly is only available to fit a 12mm & 14mm bolt at this time. Those with a 10mm fastener may wish to upgrade to 12mm hardware for more strength (drill your bracket and install a 12mm bolt).

### Assembly:

1. Verify fitment per the "Fitment" section above.
2. Insert four socket head cap screws into one end cap and one race. (Race should have spherical bore facing away from end cap.)
3. Install this small assembly into the track bar outer bushing tube. The races are a light press fit, use a wide punch and hammer to assist you if needed.
4. Apply a thin coat of multi-purpose grease to the ball and the spherical mating surface of the races. Coat both mating surfaces but leave no excess grease that would interfere with the threadlocker adhesive on the bolts.
5. Place the ball into the race inside the housing. The ball should fit the contour of the race perfectly.
6. Insert the other race on top of the ball so that the spherical bore is contacting the ball. Once again, the races are a light press fit, use a hammer and wide punch if needed. (The four screws should be through one end cap and both races at this point.)
7. Apply a generous coating of high strength threadlocker (such as red Loctite) to all 8 screws (including the ones already installed).
8. Install the second end cap, aligning the screws with the tapped holes. When completed 4 screws will be inserted from each side.
9. Insert the last four screws and tighten them all snug.
10. Torque screws in sequence using a crisscross pattern, like torquing lug nuts. Tighten all 8 screws evenly in small steps. Take your time and do not rush. Tighten all 8 screws to 20 in/lbs.



# IRON ROCK OFF ROAD

I-877-919-JEEP www.ironrockoffroad.com

JL & JT  
Sway Bar Disconnect

## Parts List:

- Front Sway Bar Link, 7.5" center to center 92246 (2)
- Passenger Side Disconnect Bracket 77080 (1)
- Passenger Side Disconnect Plate 77082 (1)
- Driver Side Disconnect Plate Small 77084 (1)
- Driver Side Disconnect Plate Large 77083(1)

## #268 – Sway Bar Disconnect Bushings (1)

- Poly Bushing 94025 (4)

## #276 – JL & JT Sway Bar Disconnect Hardware (1)

- Disconnect Pin 94028 (4)
- 1/2-20 x 1" Hex Bolt, gr8 (4)
- 1/2 F436 Hard Washer (8)
- 1/4" x 1-1/4" Spring Pin (4)
- M12 x 70 Hex Bolt (1)
- M12 x 45 Hex Bolt (1)
- M12 Nylock Nut (2)

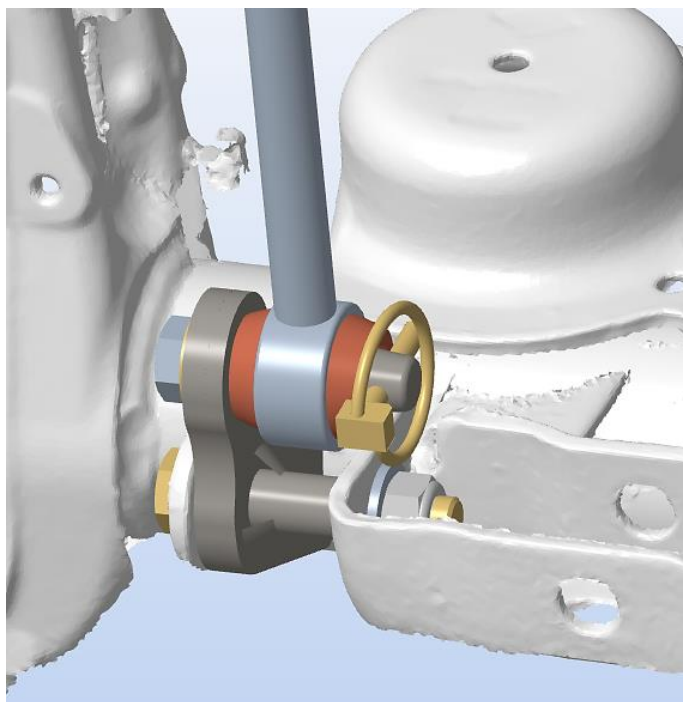
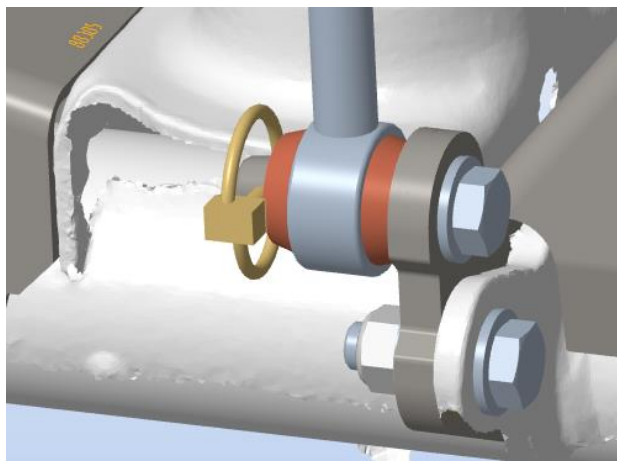
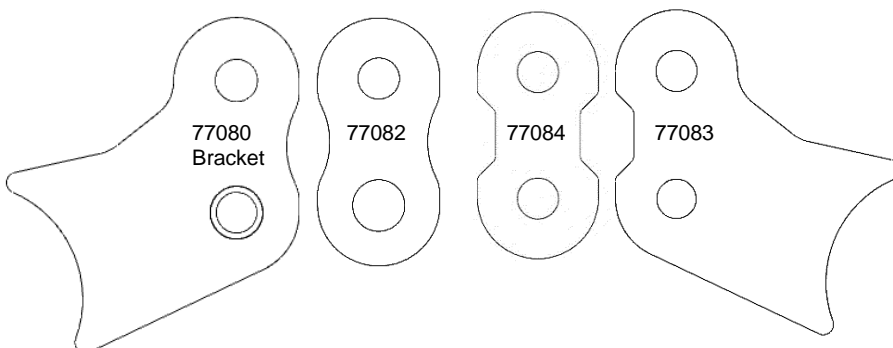

## Installation Instructions:

### Safety Warning: \*Important! Read before installation.\*

We recommend this system be installed by a qualified professional. Knowledge of suspension component function is necessary for safe installation and post installation inspections. Be sure to re-torque all suspension components after the first 100 miles of use, and frequently inspect all safety critical suspension components frequently.

### Notes:

- This kit requires Iron Rock front sway bar links from an IRO lift kit or available separately for purchase.
- Do not operate vehicle with only one side of the sway bar connected. Both sides of the sway bar must either be disconnected or both sides must be connected.

### Before you begin:

- Read all safety warnings.
- Read and understand installation instructions.
- Contact Iron Rock Off Road with any questions before, during, or after installation. 952-210-7185
- Ensure that all parts are present and in good condition using the included shipping checklist.**
- Be sure you have the following tools and supplies:
  - Floor jack and jack stands.
  - Basic hand tools (wrenches, sockets, etc.).
  - Multi-purpose grease

### **Removal of existing parts:**

1. Raise the vehicle and secure on jack stands under the front axle.
2. Remove the front tires.
3. Disconnect the front sway bar links from the axle and sway bar.
4. Remove the sleeves and bushings from the Iron Rock sway bar links.

### **Installation:**

5. Use a 1/2" drill bit to slightly enlarge the bolt hole in the sway bar. Only a very minor amount of material will be removed.
6. Install the disconnect pin on the sway bar, pin pointing out-board. Use the 1/2" x 1" bolt with a washer.  
**Tip:** Before tightening determine your desired orientation for the retaining pin.
7. Hold the disconnect pin in your desired orientation and torque the bolts to 70lb-ft.

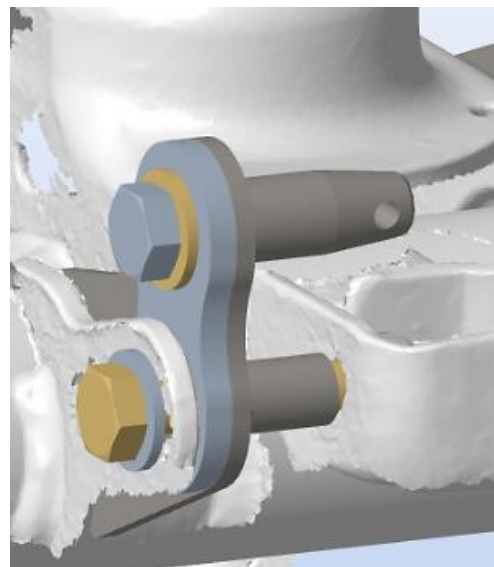
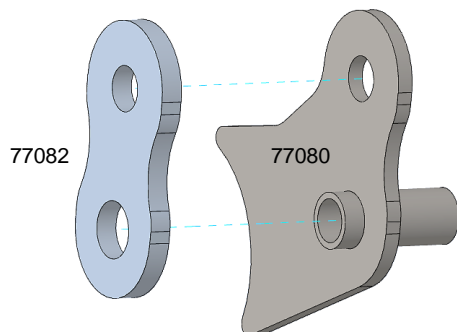

8. Align the holes and slide the plate 77082 onto the unwelded side of bracket 77080.
9. Slide the bracket assembly between the sway bar link tab and the track bar mount.
10. Install using the long M12 bolt, washers, and nylock nut.
11. Install the disconnect pin on the bracket assembly, pin pointing in-board. Use the 1/2" x 1" bolt with a washer.
12. Hold the disconnect pin in your desired orientation and torque both bolts to 70lb-ft.

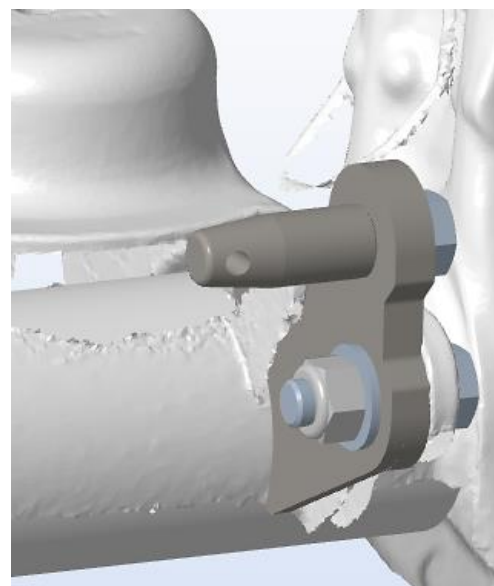
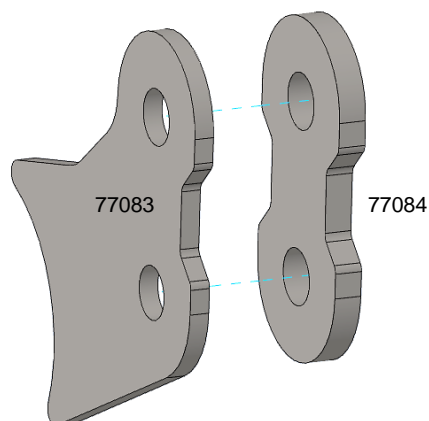

13. Align the holes in plate 77083 and plate 77084.
14. Slide the assembly between the sway bar link tab and the spring mount.
15. Install using the short M12 bolt, washers, and nylock nut.
16. Install the disconnect pin on the assembly, pin pointing in-board. Use the 1/2" x 1" bolt with a washer.
17. Hold the disconnect pin in your desired orientation and torque both bolts to 70lb-ft.
18. Install the new bushings into the sway bar links using plenty of multi-purpose grease.
19. Apply grease to the disconnect pins and slide the sway bar link onto the disconnect pins.
20. Secure the sway bar link in place using the spring pins.  
**\*NOTE:** The spring pin should take some effort to install. This is done on purpose to keep the link secure and noise free.
21. Reinstall tires and torque lug nuts to spec.
22. Lower vehicle to the ground.
23. With the vehicle back on the ground, pull the spring pins and slip the sway bar links off the disconnect pins.
24. Swing the sway bar up to its highest position.
25. Flex the suspension and steer fully left and right. Check for possible interference between the tires and sway bar.
26. Reconnect the sway bar links with the spring pins.
27. For ease of installation and best performance, re-grease the sway bar bushings periodically.

### **Final Safety Warning:**

**\*Both sides of the sway bar must be disconnected. Do not operate vehicle with only one side of the sway bar connected.**

Re-torque all fasteners after 100 miles, and frequently inspect all safety critical suspension components. It is the responsibility of the installer to ensure all fasteners are properly tightened after installation and to ensure the owner knows his/her ongoing responsibility. It is the responsibility of the owner of the vehicle to be sure all safety critical components are inspected frequently, especially after off road or other demanding use.