

IRON ROCK OFF ROAD

JL/JT 1 Ton Drag Link

1-877-919-JEEP www.ironrockoffroad.com

Parts Checklist:

- HD Drag Link 77111 (1) RUBICON OR
- HD Drag Link 77136 (1) non-RUBICON
- HD Tie Rod End 95179 (1)
- HD Anti-Flop Tie Rod End 95158 (1)
- #186 - Clamping Hardware 13312 (1)**
 - 3/8-16 X 1-1/4 Hex bolt gr8 (2)
 - 3/8-16 Nylock flange nut gr8 (2)
 - 3/8 Mil spec washer (2)
- #291 - Double Adjuster & Grease Zerks (1)**
 - Double Adjuster 95137 (1)
 - Grease Zerk 95183 (2)

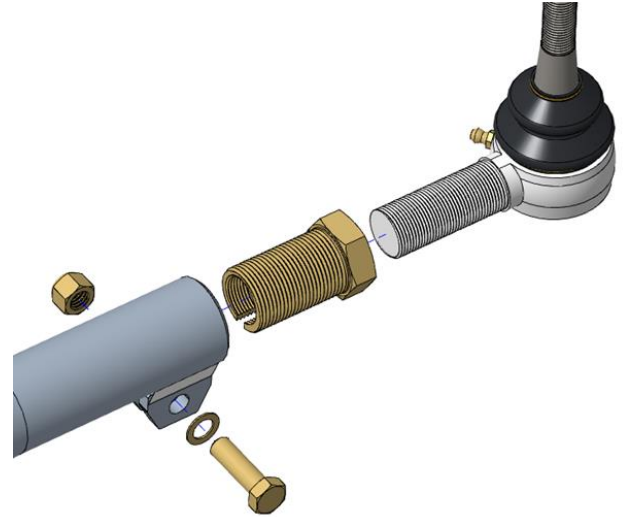

Before you begin:

- ***Ensure that all parts are present and in good condition using shipping checklist.
- Read and understand all installation instructions.
- Tools required:
 - Sockets, wrenches, ratchet
 - Anti-seize
 - Grease gun w/ multi-purpose grease
 - Torque wrench

Prepare Parts for installation:

1. Apply anti-seize to all threads.
2. Install the included grease zerk into all tie rod ends.
3. Install the double adjuster all the way into the large threaded end of the drag link. ***Reverse threads***
4. Thread one anti-flop TRE 95158 fully into the bent end of the drag link.
5. Thread one TRE 95179 fully into the double adjuster end of the drag link.
6. Install 3/8"x 1-1/4" bolt with thin washer into clamping tabs. Secure with nylock nut. Do not tighten at this time.
7. Measure center to center on existing drag link. Record lengths here: Drag Link _____
8. Roughly adjust the drag link to the existing measurements. If needed, adjust out the knuckle side tie rod end. Ensure the double adjuster end has approximately equal amounts of threads showing on the adjuster and tie rod end.

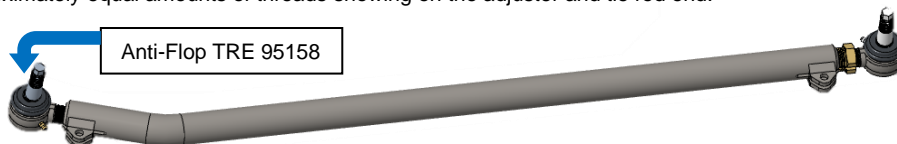

Drag Link Installation:

9. Remove the factory drag link.
 10. Install the new drag link onto the knuckle then onto the pitman arm. The drag link should bend forward when mounted.
11. **Drag Link Adjustment:**

12. Using an adjustable wrench spin double adjuster until the drag link length exactly matches your original length.
**If more than 1/2 inch of threads are exposed on double adjuster end disconnect passenger side and unthread the tie rod end 1/4 inch. **
13. Position the tie rod ends so they are in the middle of their travel. Torque the clamping bolts to 50 ft-lbs.
14. Torque nylock nuts to 50 ft-lbs.
15. Steer fully left and right and check for interferences between all the steering components.

Alignment Procedure:

16. **A professional alignment is recommended and will result in the safest handling and minimized tire wear.** As a temporary solution, with careful measurements you can set your toe-in fairly accurately using a tape measure.
17. Make sure the vehicle is on a level surface and the front tires are raised slightly off the ground with jack stands under the axle and the vehicles weight on the suspension.
18. Make a mark anywhere on the tread area of each front tire. The marks do not have to be in the same spot on each tire. This method ensures that your measurements are accurate regardless of rim and tire runout, even bent rims or untrue tires will not affect the measurement.
19. Measure from one mark to the other making sure your measurement is parallel to the axle housing and your marks are facing exactly forward. This is your front measurement.
20. Rotate tires so the marks are facing exactly backward. Measure from one mark to the other making sure your measurement is parallel to the front axle housing. This is your rear measurement.

For 29-32" tire diameter (measured): adjust your tie rod until the front measurement is 1/16" less than your rear measurement.

- For 33-36" tire diameter** (measured): adjust your tie rod until the front measurement is 1/8" less than your rear measurement.
21. Re-check your measurements.
 22. Lower your vehicle from the jack stands.
 23. Double check to ensure that all fasteners are tight.
 24. Re-torque all fasteners frequently.

Steering wheel alignment:

25. Ensure all fasteners are torqued to spec.
26. Go for a short test drive.
27. Note steering wheel angle when driving straight and steady.
28. Drive straight into your working area making sure steering wheel angle matches angle during test drive.
29. Loosen only the double adjuster clamp on drag link.
30. Turn only the double adjuster until steering wheel is straight.
31. Position the tie rod ends so they are in the middle of their travel. Torque the clamping bolts to 50 ft-lbs.
32. Test drive again, recheck steering wheel angle.
33. Repeat steps if necessary.

Final Safety Warning:

* Re-torque all fasteners after 100 miles, and frequently inspect all safety critical steering components. It is the responsibility of the installer to ensure all fasteners are properly tightened after installation and to ensure the owner knows his/her ongoing responsibility. It is the responsibility of the owner of the vehicle to be sure all safety critical components are inspected frequently, especially after off road or other demanding use.