

# IRON ROCK OFF ROAD

1-877-919-JEEP www.ironrockoffroad.com

**JT 5" Rock-Link PRO  
Lift Kit Instructions**

See our website product listing for full color instructions

## Parts Checklist:

- Iron Rock Off Road Logo Decal 10001 (1)
- Ironrockoffroad.com decal (1)
- 5" Front coil spring 96040 (2)
- 5" Rear coil spring 96042 (2)
- Rear sway bar link 11.25" center to center 92147 (2)
- JT Rear Bump Stop Spacer 2" 77026 (2)
- Stackable Bump Stop Set
  - 1 Inch Top Bump Stop 88271 (2)
  - 1/2 Inch Bump Stop Spacer 88272 (2)
  - 1 Inch Bump Stop Spacer 88273 (2)
  - 1-1/2 Inch Bump Stop Spacer 88274 (2)
- #192 - Stackable Bump Stop Hardware (1)**
  - 7/16 x 1 1/2" hex bolt, gr5 (2)
  - 7/16 x 2 1/2" hex bolt, gr5 (2)
  - 7/16 x 3 1/2" hex bolt, gr5 (2)
  - 7/16 x 4 1/2" hex bolt, gr5 (2)
  - 7/16 flag nut 80063 (2)
- #199 - JT Rear Bump Stop Spacer Hardware (1)**
  - 5/16-18 x 3/4 Serrated flange bolt, gr8 (4)
  - 5/16-18 Serrated flange nut (4)
- #201 - Sway Bar Link Hardware (1)**
  - 3/4" hourglass bushing 94025 (4)
  - 12mm sway bar bolt sleeve 92038 (4)
  - M12 x 65 Hex bolt cl 10.9 (2)
  - M12 Nylock nut (2)
  - 7/16 USS washer (4)
- Long arm mount, passenger side 77053 (1)

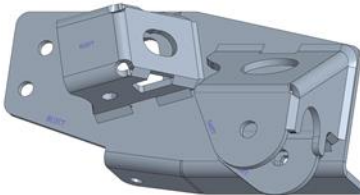

- Long arm mount, driver side 77036 (1)

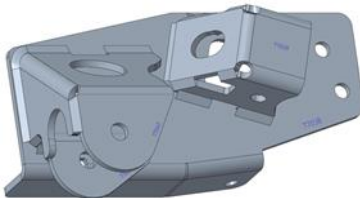

- LCA, **16mm** bushing installed 77049 (2)
  - LCA, Angled Threaded male end 91109 (2)

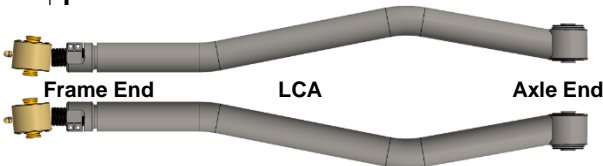

- UCA Passenger Side 77047 (1)
- UCA Driver Side 77046 (1)
- UCA Front threaded male end 77131 (2)

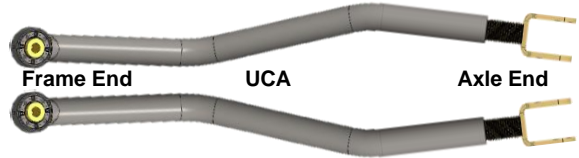

- #65 - Adjustable LCA Clamping Hardware - 10058 (1)**
  - 1/4"-28 x 1-1/8" socket head cap screw (4)
  - 1/4"-28 hex nut, gr8 (4)
- #168 - 2 3/8" 8 Bolt IRO Flex End Hardware - 13261 (2)**
  - Inner race 91139 (2)
  - Thrust washer 91138 (2)
  - 2-3/8" Flex End Ball 91140 (1)
  - 8-32 x 1-1/2" Socket Head Cap Screw (8)
  - 90 Degree 1/4"-28 Grease Zerk Fitting (1)
- #186 - UCA Clamping Hardware - 13312 (1)**
  - 3/8-16 X 1-1/4 Hex bolt gr8 (2)
  - 3/8-16 Nylock flange nut gr8 (2)
  - 3/8 Mil spec washer (2)
- #233 - 2 5/8" 6 Bolt IRO Flex End Hardware - 14139 (2)**
  - Inner race 91118 (2)
  - Thrust washer 91119 (2)
  - 2-5/8" Flex End Ball 16mm bolt 91242 (1)
  - 10-32 x 1-3/4" Socket Head Cap Screw (6)
  - 10-32 Nylock Nut (6)
  - 1/4"-28 90° Grease zerk Fitting (1)
- #247 - Long Arm Bracket Hardware - 14410 (1)**
  - Two-Bolt Nut Plate 77042 (2)
  - One-Bolt Nut Plate 77052 (2)
  - 1/2 x 1-1/2" hex bolt, gr8 (2)
  - 1/2 F436 washer (2)
  - 1/2 nylock flange nut (2)
  - M14 x 35 hex bolt, class 10.9 (6)
  - 9/16" F436 hardened washer (8)
  - M14 nylock flange nut class 10.9 (2)
  - M14 x 100 hex bolt class 10.9 (2) UCA bolts

## Rear Long Arm Parts

- Rear Long arm mount, driver side 77075 (1)

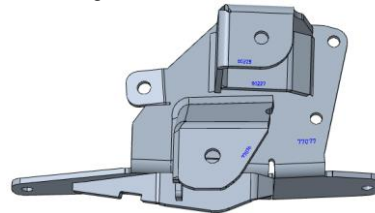

- Rear Long arm mount, passenger side 77085 (1)

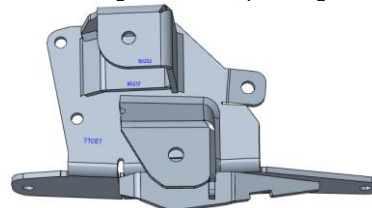

- Bolt-on LCA ramp, driver side 77078 (1)
- Bolt-on LCA ramp, passenger side 77088 (1)
- Rear LCA, Driver, **16mm** bushing installed 85110 (1)
- Rear LCA, Passenger, **16mm** bushing installed 85109 (1)
  - LCA, Angled Threaded male end 91109 (2)

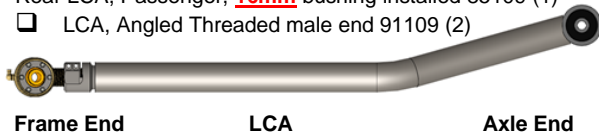

Frame End                      LCA                      Axle End

- Rear UCA Driver Side 77098 (1)
- Rear UCA Passenger Side 77109 (1)
  - UCA threaded male end **16mm** bushing installed, 91243 (2)

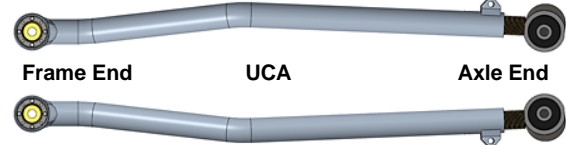

Frame End                      UCA                      Axle End

- #65 - Adjustable LCA Clamping Hardware – 10058 (1)**
  - 1/4"-28 x 1-1/8" socket head cap screw (4)
  - 1/4"-28 hex nut, gr8 (4)

- #168 - 2 3/8" 8 Bolt IRO Flex End Hardware – 13261 (2)**
  - Inner race 91139 (2)
  - Thrust washer 91138 (2)
  - 2-3/8" Flex End Ball 91140 (1)
  - 8-32 x 1-1/2" Socket Head Cap Screw (8)
  - 90 Degree 1/4"-28 Grease Zerk Fitting (1)
  - 1/4"-28 Straight Grease Zerk (1)

- #186 - UCA Clamping Hardware – 13312 (1)**
  - 3/8-16 X 1-1/4 Hex bolt gr8 (2)
  - 3/8-16 Nylock flange nut gr8 (2)
  - 3/8 Mil spec washer (2)

- #233 - 2 5/8" 6 Bolt IRO Flex End Hardware – 14139 (2)**
  - Inner race 91118 (2)
  - Thrust washer 91119 (2)
  - 2-5/8" Flex End Ball **16mm** bolt 91242 (1)
  - 10-32 x 1-3/4" Socket Head Cap Screw (6)
  - 10-32 Nylock Nut (6)
  - 1/4"-28 90° Grease zerk Fitting (1)

- #282 – Rear Long Arm Bracket Hardware – 15443 (1)**
  - Bolt Plate 1/2" x 1-1/2" bolt 77090 (4)
  - 1/2 nylock flange nut (4)
  - Fish Wire - 1/2" bolt size, bag 58400 (2)
  - Short M14 Nut Plate 77052 (4)
  - Long M14 Nut Plate 77096 (2)
  - M14 x 35 hex bolt, class 10.9 (6)
  - M14 x 90 hex bolt class 10.9 (2) UCA bolts
  - 9/16" F436 hardened washer (10)
  - M12-1.25 x 45 hex bolt class 10.9 (2)
  - 7/16 F436 hardened washer (2)
  - M16 x 110 hex bolt class 10.9 (2) LCA bolts
  - M16 nylock flange nuts (2)

- JT 0-8" front track bar 77016 (1)
- Track bar threaded male end, Flex Joint 77128 (1)

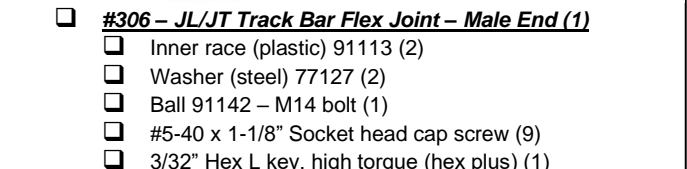

**Standard Track Bar**

- #235 - Front Track Bar Hardware (1)**
  - Track bar bushing half 80014 (2)
  - Track bar bushing sleeve 80003 (1)

- Track Bar clamp 95044 (1)
  - 5/16-18 x 2 carriage bolt gr5 (1)
  - 5/16-18 hex flange nut (1)
- ~Optional Premium Track Bar Upgrade~**
- #254 - Track Bar Flex End Hardware - 14mm (1)**
    - Inner race (plastic) 91113 (2)
    - End cap (steel) 91112 (2)
    - Ball 91142 – M14 bolt (1)
    - #5-40 x 1 1/4" Socket head cap screw (9)
    - 3/32" Hex L key, high torque (hex plus) (1)
  - #281 - Track Bar Clamp Hardware (1)**
    - Track Bar clamp 95044 (1)
    - 5/16-18 x 2 carriage bolt gr5 (1)
    - 5/16-18 hex flange nut (1)



- JT 0-8" rear track bar 77031 (1)
- Standard Track Bar**
- Track bar threaded male end 92004 (1)
  - #236 - Rear Track Bar Hardware (1)**
    - Track bar bushing half 80014 (4)
    - Track bar bushing sleeve 80003 (2)
    - Track Bar clamp 95044 (1)
    - 5/16-18 x 2 carriage bolt gr5 (1)
    - 5/16-18 hex flange nut (1)

- ~Optional Premium Track Bar Upgrade~**
- Track bar threaded male end, Flex Joint 77128 (1)
  - #254 - Track Bar Flex End Hardware - 14mm (1)**
    - Inner race (plastic) 91113 (2)
    - End cap (steel) 91112 (2)
    - Ball 91142 – M14 bolt (1)
    - #5-40 x 1 1/4" Socket head cap screw (9)
    - 3/32" Hex L key, high torque (hex plus) (1)
  - #306 – JL/JT Track Bar Flex Joint – Male End (1)**
    - Inner race (plastic) 91113 (2)
    - Washer (steel) 77127 (2)
    - Ball 91142 – M14 bolt (1)
    - #5-40 x 1-1/8" Socket head cap screw (9)
    - 3/32" Hex L key, high torque (hex plus) (1)
  - #281 - Track Bar Clamp Hardware (1)**
    - Track Bar clamp 95044 (1)
    - 5/16-18 x 2 carriage bolt gr5 (1)
    - 5/16-18 hex flange nut (1)

- ~Standard Front Sway Bar Links~**
- Front sway bar link 8.75" center to center 92145 (2)
  - #201 - Sway Bar Link Hardware (1)**
    - 12mm sway bar bolt sleeve 92038 (4)
    - 3/4" hourglass bushing 94025 (4)
    - M12 x 65 Hex bolt cl 10.9 (2)
    - M12 Nylock nut (2)
    - 7/16 USS washer (4)



- ~Optional Front Sway Bar Disconnect Upgrade~**
- Front Sway Bar Link, 7.5" center to center 92246 (2)
  - Passenger Side Disconnect Bracket 77080 (1)
  - Passenger Side Disconnect Plate 77082 (1)
  - Driver Side Disconnect Plate Small 77084 (1)
  - Driver Side Disconnect Plate Large 77083(1)
  - #268 – Sway Bar Disconnect Bushings (1)**
    - Poly Bushing 94025 (4)
  - #276 – JT Sway Bar Disco. Hardware (1)**
    - Disconnect Pin 94028 (4)
    - 1/2-20 x 1" Hex Bolt, gr8 (4)
    - 1/2 F436 Hard Washer (8)
    - 1/4" x 1-1/4" Spring Pin (4)
    - M12 x 70 Hex Bolt (1)
    - M12 x 45 Hex Bolt (1)
    - M12 Nylock Nut (2)



## Shocks

### Trail Tamer HD Hydro

- Front shock 79005 (2)
- Rear shock 79005 (2)

### #255 – JT Shock Hardware (1)

- Front Upper Shock Sleeve 79012 (2)
- Front Upper Shock Mount Spacer 79013 (4)
- Rear Shock Sleeve, M14 79014 (4)
- Rear Shock Bushing, 94025-BK-01 (4)
- M12 x 70 Hex bolt cl 10.9 (2)
- M12 Nylock nut (2)
- 7/16 USS washer (4)

### Doetsch Upgrade (Optional)

- Front shock DT 8371 (2)
- Rear shock DT 8371 (2)

### #255 – JT Shock Hardware (1)

- Front Upper Shock Sleeve 79012 (2)
- Front Upper Shock Mount Spacer 79013 (4)
- Rear Shock Sleeve, M14 79014 (4)

- Rear Shock Bushing, 94025-BK-01 (4)
- M12 x 70 Hex bolt cl 10.9 (2)
- M12 Nylock nut (2)
- 7/16 USS washer (4)

### Bilstein Upgrade (Optional)

- Front shock 33-104652 (2)
- Rear shock 33-104652 (2)

### #231 – JL Bilstein Shock Hardware (1)

- 12mm X 1.49" Shock Sleeve 79008 (4)

### #255 – JT Shock Hardware (1)

- Front Upper Shock Sleeve 79012 (2)
- Front Upper Shock Mount Spacer 79013 (4)
- Rear Shock Sleeve, M14 79014 (4)
- Rear Shock Bushing, 94025-BK-01 (4)
- M12 x 70 Hex bolt cl 10.9 (2)
- M12 Nylock nut (2)
- 7/16 USS washer (4)



Install video on





**Safety Warning: \*\*\*Important! Read before installation. \*\*\***

We recommend this system be installed by a qualified professional. Knowledge of suspension component function is necessary for safe installation and post installation inspections. Be sure to re-torque all suspension components after the first 100 miles of use, and frequently inspect all safety critical suspension components.

**Before you begin:**

- \*\*\*Ensure that all parts are present and in good condition using above shipping checklist.\*\*\*
- Read and understand all installation instructions.
- Tools required:
  - Floor jack and jack stands
  - Basic hand tools
  - 3/4" crow's foot or 3/4" flex head wrench
  - Torque wrench
  - Angle grinder, Sawzall
  - Anti-seize compound.
  - Multipurpose grease
  - Tape measure
  - 1/2" drill bit and drill



3/4" crow's foot



3/4" flex head wrench

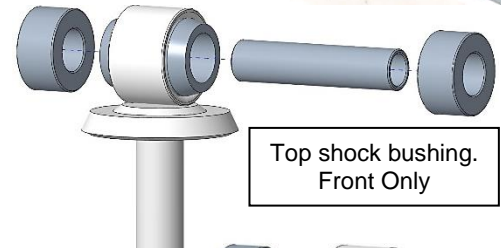

Top shock bushing. Front Only

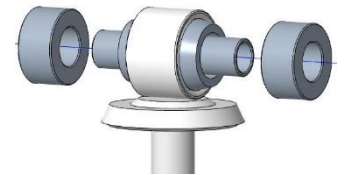

**Prepare the parts for installation:**

1. **Front Shocks:** Locate the front shocks (same length front and rear) and **HK #255**.
2. Grease and install the long sleeve into the top bushing of the front shocks. The long sleeve should be approximately in the center of the bushing.
3. Grease and install the short shock sleeves (included with shocks) into the bottom bushing.
4. **Rear Shocks:** Locate the rear shocks (same length front and rear) and **HK #255**.
5. Remove the bushings from the included shocks.
6. Grease and install the new shock bushings.
7. Grease and install the new M14 shock sleeves.
8. **Track Bars:** Locate front track bar, **HK #235** and track bar threaded male end with joint installed.
9. If you purchased the **Premium Track Bar Upgrade** refer to the track bar flex joint assembly instructions at the end of this document.
10. Locate rear track bar, **HK #236** and track bar threaded male end.
11. Lubricate track bar bushings and bushing sleeves with multi-purpose grease and install into track bars.
12. Slip clamping bracket onto adjusting end of track bar with the opening up and insert the 5/16 carriage bolt from rear and nut facing forward.
13. Apply anti-seize and thread the track bar male end into the track bar and adjust to length listed in the chart as a starting point.
14. Tighten the clamping bracket.
15. **Adjustable Control Arms:** Using the instructions on the last page assemble the flex ends into the threaded male ends for LCAs and rear UCAs. LCAs use **HK #233**, the UCAs use **HK #168**.
16. Use a light coat of anti-seize then thread the male ends into the control arms and adjust to the lengths in the chart as a starting point.
17. Install the clamping bolts **HK #65** into the LCAs and rear UCAs. **HK #186** into the front UCAs, do not fully tighten at this time.

Control Arm Length (Center to Center)	
Front UCA (Upper Control Arm)	34-3/4"
Front LCA (Lower Control Arm)	38"
Rear UCA	34-1/4"
Rear LCA	37-1/2"
Front Track Bar	33-7/8"
Rear Track Bar	33-3/4"

18. **Sway Bar Links:** Grease and install the hourglass bushings into the links. **HK #201**
19. If you purchased the **IRO Sway Bar Disconnect Upgrade** refer to the assembly instructions at the end of this document.
20. Grease and install the sway bar link bolt sleeves into the bushings. All sleeves are the same (12mm I.D.).

**Front installation:**

21. Lift front of vehicle and support with jack stands under frame rails.
22. Support the axle with jack stands.
23. Remove front wheels, sway bar links, track bar, shocks, and coil springs.
24. Install new front track bar, threaded end to axle side. The clamp faces up, nut facing front.
25. Install new shocks with a new M12 x 70 bolt at the bottom. **HK #255**
26. Remove the factory T-Brace from the frame. Save the M12 bolts for future use.
27. Remove the factory upper and lower control arms. Save the LCA M16 bolts and UCA M12 bolts for future use.

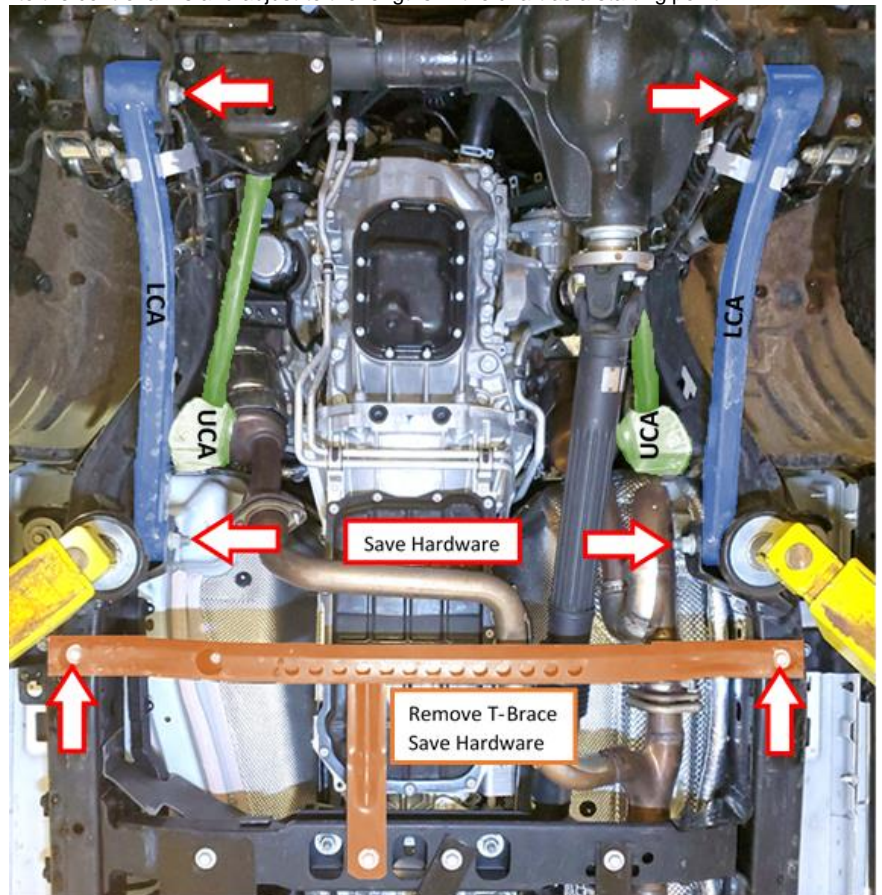

Save Hardware

Remove T-Brace Save Hardware



28. **Diesel Only:** The sensor on the side of the frame needs to be relocated to the top of the frame.



29. Remove the heat shield from the sensor, then remove the nuts securing it to the frame. Pop the sensor off the mounting plate.



30. Disconnect the plastic harness track from the frame by popping the plastic tree plug out of the frame. Place the sensor on top of the frame and zip tie it to the plastic harness track.



31. Tuck the plastic harness track above the frame.



32. Grind the mounting studs off the frame and continue with the installation.



33. Remove the panel from in front of the gas tank and grind the stud flush with the frame.

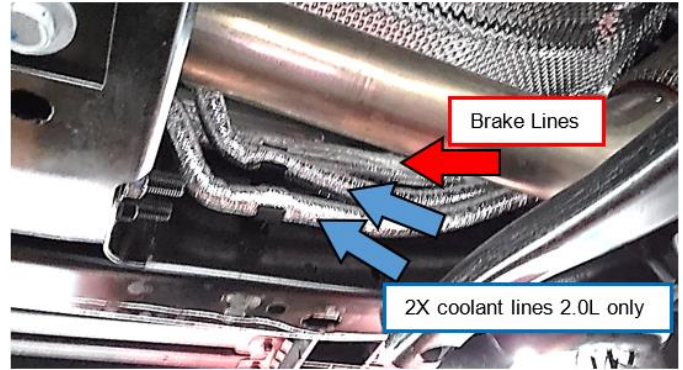

34. Temporarily disconnect the brake lines (and coolant lines on 2.0L) from the Driver's side frame and tie them out of the way for cutting/grinding.

35. Cut off the front upper and lower control arm mounts from the frame. Do not cut into the frame. Ensure the frame is completely smooth, clean, and ready for painting.

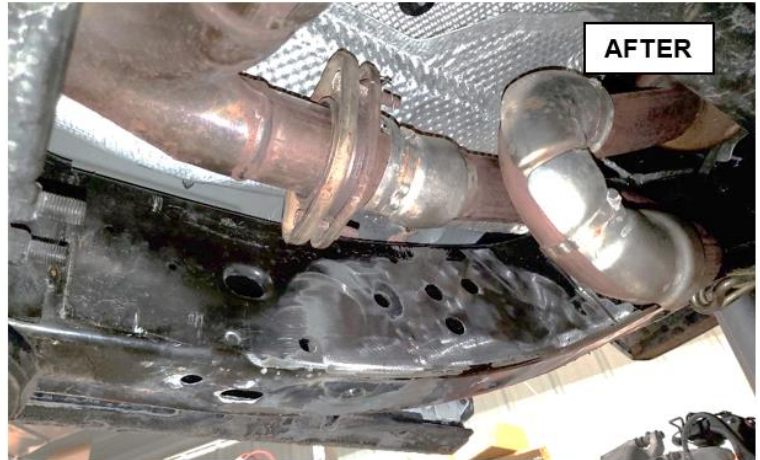
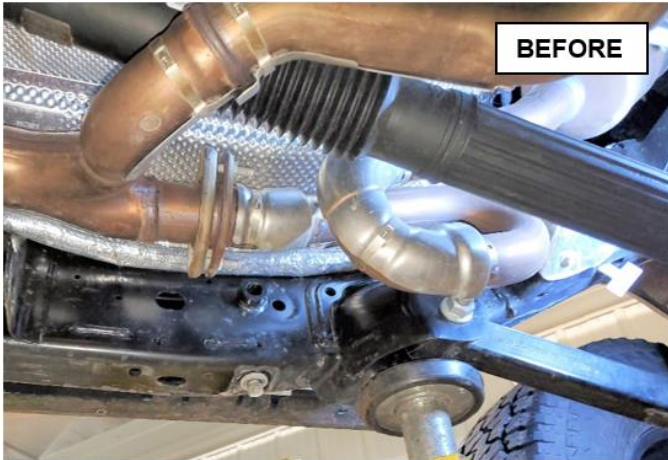

36. **2.0L Turbo Only:** The 2 coolant lines need to be repositioned to the top of the frame. IRO recommends cutting the hard lines and using rubber heater hose to make repositioning easiest. It may be possible to bend the hard lines upward for clearance but there is risk of damage to the lines.

37. **Long Arm Mounting Brackets:** Locate long arm brackets and HK #247.

38. Align the crossmember mounting brackets on the frame by installing the factory M12 bolts through the bottom of the bracket and the matching threaded hole in the frame.

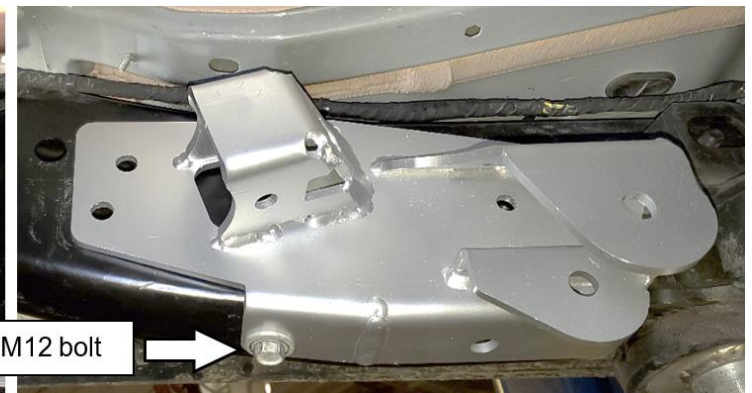
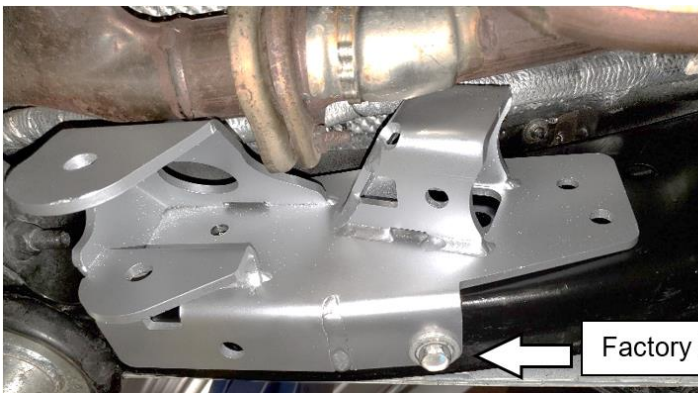

Factory M12 bolt



39. **Driver Side:** Using a 1/2" drill bit, drill the rear upper mounting hole from the outside of the frame. \*Note\* If your Jeep is equipped with factory rock sliders, the driver's side rock slider needs to be removed temporarily for adequate drill clearance or use a right angle drill.
40. Drill the small factory hole inside the oval slot to 1/2" with the long arm bracket in place.



41. **Passenger Side:** Drill the rear upper mounting hole from the inside of the frame using the long arm bracket as a guide. Use a 1/2" drill bit.



M14 class 10.9

1/2" Grade 8

42. Install the 1/2" grade 8 bolt with a washer through the bracket and install the matching flange lock nut inside the frame.
43. Use a crow's foot on an extension or a flex head wrench to install the nut onto the bolt. Torque to 100 lb-ft.

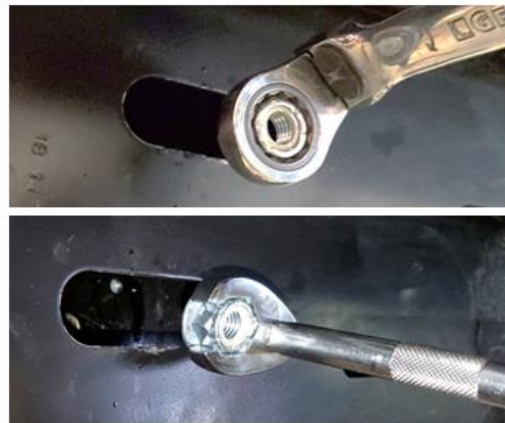

44. Install the two-bolt nut plate through the large hole in the frame inside the body mount bracket. Use a supplied M14 x 100 bolt and standard M14 nut to hold the nut plate while threading the M14 x 40 bolts into the nut plate. Remove the M14 x 100 bolt after the first short M14 bolt is started.



45. Thread the M14 x 40 bolts with washers into the two-bolt nut plate. Torque to 100 lb-ft.



46. Align a single-bolt nut plate above the bottom hole in the long arm bracket and install a M14 x 40 bolt and washer. Torque to 100 lb-ft.
47. Torque the factory M12 bolt to 100 lb-ft.

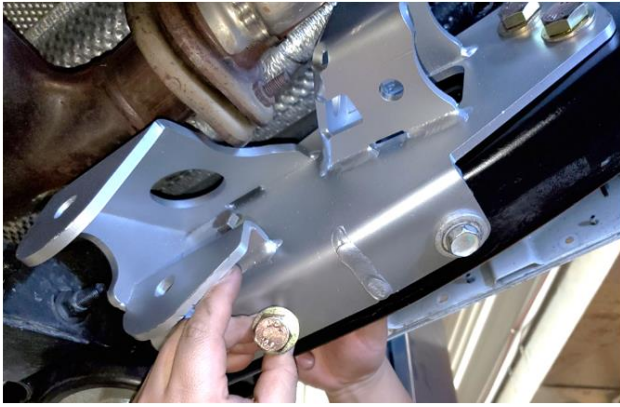

48. **Upper Control Arms:** Locate the upper control arms and M14 x 100 bolts, washers, and flange lock nuts.
49. Install the flex end of the upper control arm into the long arm mounting bracket then install the fork end onto the axle.
50. The arm is bent for frame and exhaust clearance; the clamping bolt points down.
51. Secure the upper control arms with the M14 x 100 bolts, washers, and flange lock nuts at the long arm bracket.
52. Use the factory M12 bolts and nuts at the axle end. Torque the M14 bolts to 120 lb-ft. Do not tighten the M12 bolts at this time.



53. **Lower Control Arms:** Locate the lower control arms and the factory M16 bolts.
54. Install the rubber bushing at the axle then install the flex end at the frame. The LCAs are bent inward for tire clearance.
55. Torque bolts at the frame to 130 lb-ft. Do not tighten bolts at the axle at this time.

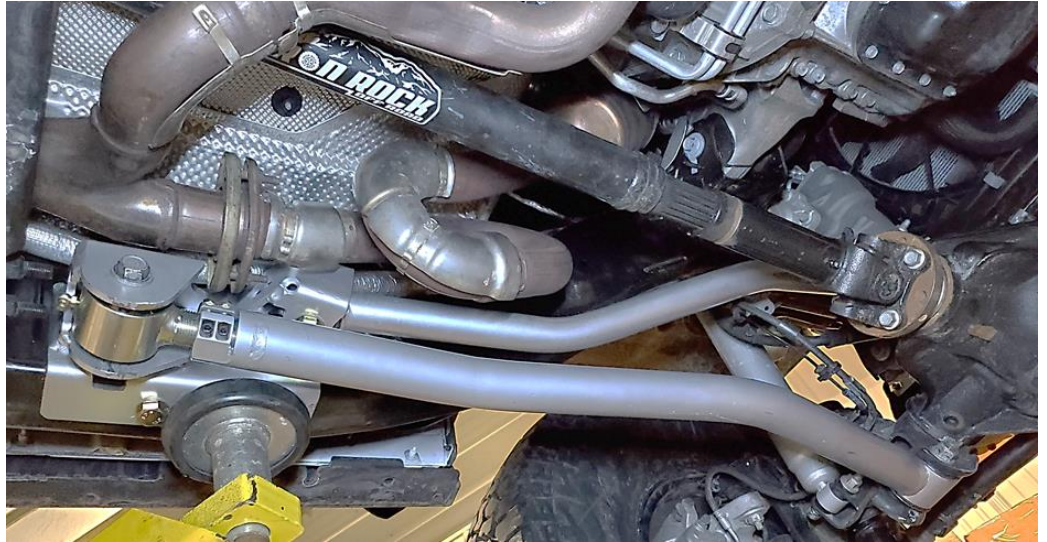
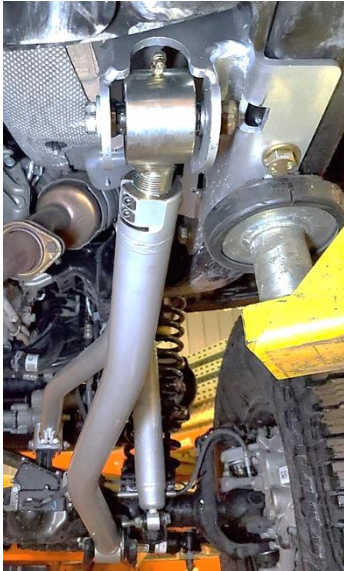

56. Ensure that the lower control arm flex ends are oriented properly in the mounts. The male ends are angled to match the angle of the axle mounts.

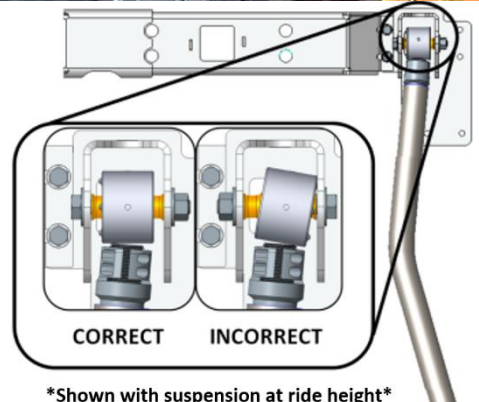
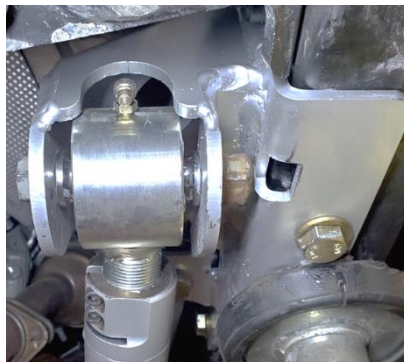

\*Shown with suspension at ride height\*



### **Front Adjustable Bump Stops:**

Determine your desired bump stop height. IRO recommends 3" as a starting point. Bump stop height is determined by many variables: tire size, wheel offset, fender clearance, fender trimming.

57. Stack bump stop top and spacers to achieve desired height and align them with the correct bolt length. **HK #192**
58. Drill out the existing hole in the center of your lower spring mount with a 7/16 drill bit.
59. Position the flag nut under the spring mount, aligning the nut with the drilled hole.  
\*\*You may have to bend the flag nut slightly.\*\*
60. Apply a small amount of medium strength thread locker to bump stop bolt and install into flag nut.
61. Ensure the bolt hex engages the hex in the top bump stop.
62. Spin the bump stop stack until tight. An oil filter wrench works well for this. Do not over-tighten, let the threadlocker do most of the work.
63. \*\*To maximize your suspension flex: Reconnect the shocks to the axle and temporarily install tires.
64. With the shocks connected and springs out, use a jack to check suspension articulation left and right, as well as both sides fully compressed. Turn the wheels left and right while suspension is articulated.
65. \*\*If interference between the tires and body is found adjust bump stop height or trim body work accordingly.
66. Install new coil springs.
67. Install new front sway bar links.
68. Lower vehicle onto jack stands under the front axle.



Bump Stop Height	Bolt Length
4.0 Inch	4.5"
3.5 Inch	
3.0 Inch	3.5"
2.5 Inch	
2.0 Inch	2.5"
1.5 Inch	
1.0 Inch	

### **Rear Installation:**

69. Lift rear of vehicle and support with jack stands under frame rails.
70. Support the axle with jack stands.
71. Remove the two factory M12 bolts from the gas tank skid plate. Pry the tank skid down slightly, insert the long arm bracket, and reinstall the bolts.
72. Install the long arm bracket on the opposite side of the frame using the two M12 x 45 bolts from **HK #282**.
73. With the M12 bolts tight, mark the location on the frame where the two holes need to be drilled.

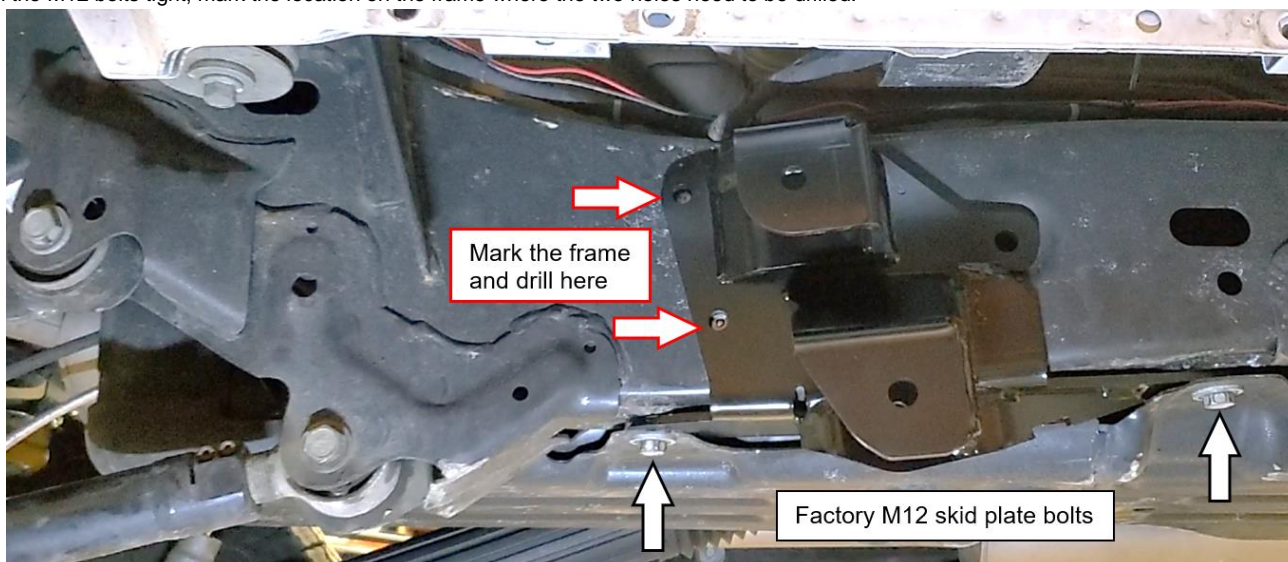

74. Remove the bracket and drill the 1/2" holes through only the outside surface of the frame. Be sure to remove any sharp edges.
75. Reinstall the bracket and check that the bracket aligns with the drilled holes.  
\*Tip: run the drill through the bracket and frame to ensure perfect hole alignment.
76. Remove the factory upper and lower control arms. Save the M16 nuts and bolts for future use.
77. Cut off the upper and lower control arm mounts from the frame. Remove brackets in pieces. Do not cut into the frame. A combination of grinder, sawzall, hammer and chisel is preferred. Use caution near the fuel tank!

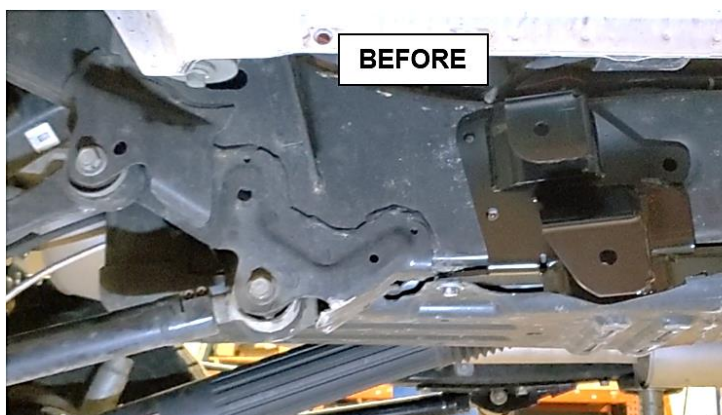



78. Trim the body mount: measure up approximately 1 inch from the bottom of the reinforcement plate and mark a horizontal line. Mark a vertical line beside the weld to the bottom of the reinforcement plate. From the bottom of the reinforcement plate, mark a line parallel to the edge of the body mount bracket. Do not cut into any of the welds on the body mount. Ensure the frame is completely smooth, clean, and ready for painting.

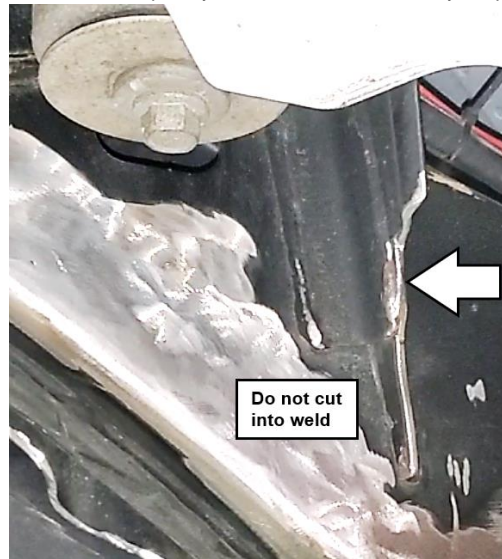
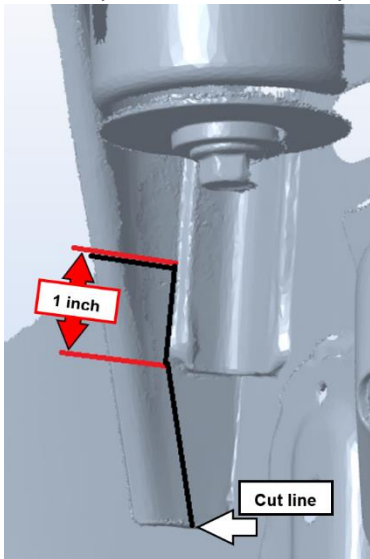

79. With the frame painted and dry locate the Fish Wire in **HK #282**.

80. Insert the coiled end of the fish wire into one of the drilled holes, pushing the wire forward to the large oval opening in the frame.

81. Thread a bolt plate 77090 into the coiled end of the fish wire then pull it through the frame and out of the drilled hole. Leave the fish wire attached.

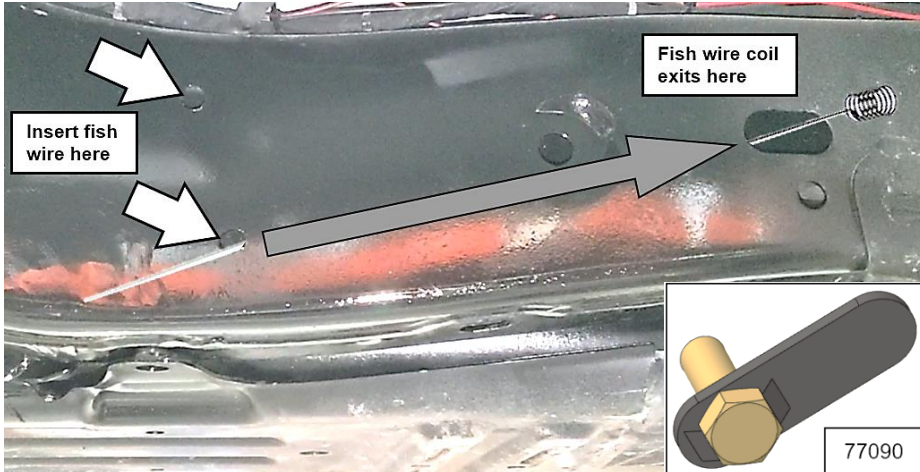

82. **Long Arm Mounting Brackets:** Locate long arm brackets and **HK #282**.

83. Install the bracket on the frame by putting the tail of a fish wire through its matching hole in the bracket. Use the fish wire to pull the bolt plate into the bracket. Secure the bracket in place with 1/2" nylock flange nuts on the bolt plates and M12 bolts through the bottom of the frame. Torque M12 and 1/2" hardware to 100 ft-lbs.

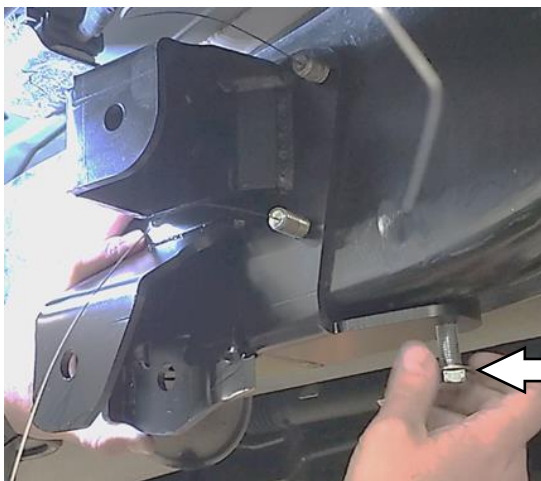



84. Align the short M14 nut plate 77052 onto the bottom hole in the bracket. Insert the fish wire into the bottom hole of the bracket and out through the oval hole in the side of the frame. Slide the nut plate onto the fish wire to guide it directly to the bolt hole. Be sure to position the nut plate with the nut on top of the plate. Use a supplied M14 x 35 bolt with F436 washer to secure it in place. Torque to 100 ft-lbs.

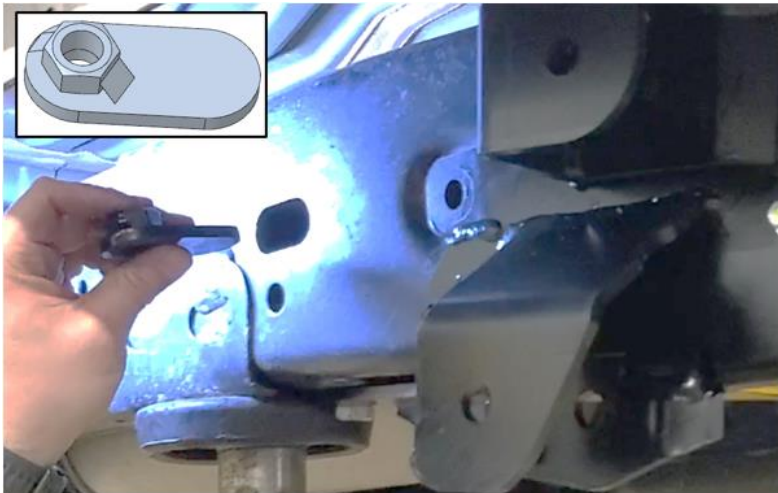
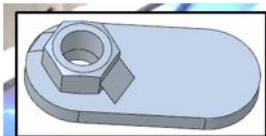

85. Locate the LCA ramp bracket 77078, 77088, and a short nut plate.  
 86. Place a F436 washer on a M14 x 35 bolt and put it through the smaller hole in the LCA ramp bracket. This is the frame side of the bracket.  
 87. Align the nut plate with the frame hole just below the oval opening in the frame and attach the LCA ramp loosely. The other end of the bracket will be installed with the LCA bolt.  
 88. Locate the long M14 nut plate and a M14 x 35 bolt and F436 washer. Insert the nut plate into the oval opening and align it with the dimpled pocket in the frame and the hole in the long arm bracket. Install the M14 bolt with washer. Torque all M14 hardware to 100 lb-ft.

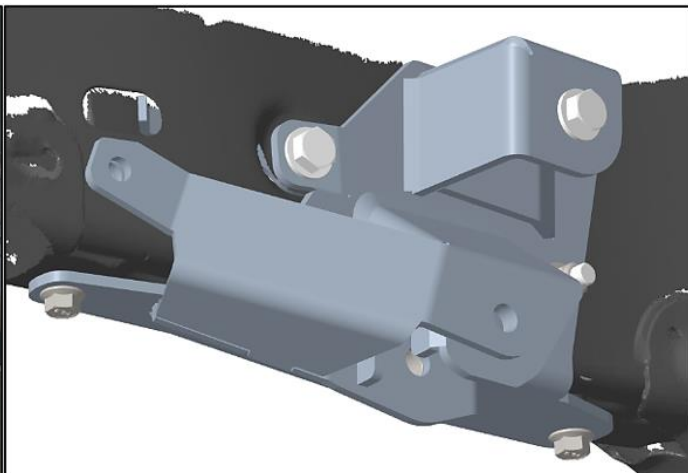

89. **Upper Control Arms:** Locate the upper control arms, M14 x 90 bolts, and F436 washers.  
 90. Install the flex end of the UCA into the long arm basket using the M14 bolt, then install the rubber bushing end onto the axle with the original bolt.  
 91. The rubber bushing male end is angled to match the angle of the UCA mount on the axle. The arm is bent down and outward for frame clearance, the clamping bolt points down.  
 92. Torque the UCA bolts at the frame to 120 lb-ft. Do not tighten the axle side rubber bushing bolts at this time.  
 93. **Lower Control Arms:** Locate the lower control arms, new M16 bolts, nylock flange nuts, and the factory M16 bolts and nuts.  
 94. Install the flex end at the frame then install the rubber bushing at the axle. Use the new M16 bolt, F436 washer and flange lock nut at the frame. Install the LCA at the frame with the ramp skid bracket in place. The LCAs are bent outward for frame clearance and upward for ground clearance. The flex joint male end is angled to match the angle of the LCA mount on the frame.  
 95. Torque LCA bolts at the frame to 130 lb-ft. Do not tighten rubber bushing bolts at the axle at this time.

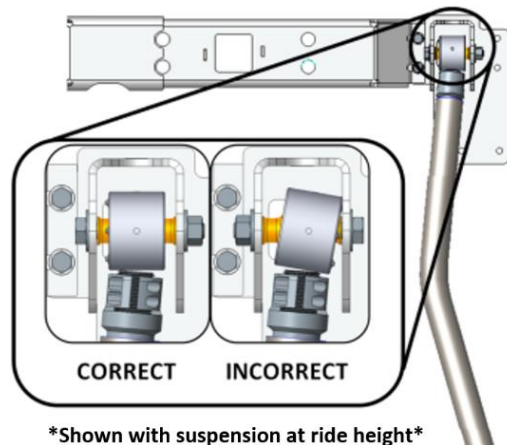

\*Shown with suspension at ride height\*



### **Final Torque and Adjustments:**

96. Raise vehicle and reposition jack stands under the front and rear axles so that the weight of the vehicle is on the suspension.
97. Temporarily install a tire on one side.
98. Verify that the axle is centered as desired front to rear.
99. Check pinion angle. Bounce the Jeep up and down to ensure the suspension is in resting position (at exact ride height). If your Jeep is equipped with the original driveshaft, (with the rezeppa joints at both ends) matching the pinion angle to the carrier bearing isn't critical. Within 2-3° is ok.
100. Adjust control arms to the desired position.
101. To adjust axle front to rear, adjust lower control arms by the same amount. 12 turns equal one inch.
102. To adjust pinion angle, adjust only the upper control arms (3 turns equals roughly 2 degrees).
103. To adjust both, adjust both at the same time.
104. With the vehicle weight on the suspension, tighten the upper and lower control arm bolts at the axle to 130 lb-ft.
105. Torque the lower control arm clamping bolts to **140 in-lb**. Be sure to go back and forth between both bolts several times to ensure even clamping.
106. Torque the upper control arm clamping bolts to
107. Install tires and wheels. Torque lug nuts to spec. (Typical specification is 85-115 ft-lbs., depending on your wheels)
108. Recheck all fasteners and torque any remaining loose nuts or bolts to spec.
109. Check all components for clearance for suspension to fully cycle up and down and wheels to turn lock to lock. Pay special attention to brake lines, axle vent hoses, and ABS wires. Reposition as needed by bending the brackets, relocating, or extending hoses and wiring.

### **Final Safety Warning:**

110. \* Re-torque all fasteners after 100 miles, and frequently inspect all safety critical suspension components. It is the responsibility of the installer to be sure all fasteners are properly tightened after installation and to ensure the owner knows his/her ongoing responsibility. It is the responsibility of the owner of the vehicle to be sure all safety critical components are inspected frequently, especially after off road or other demanding use.

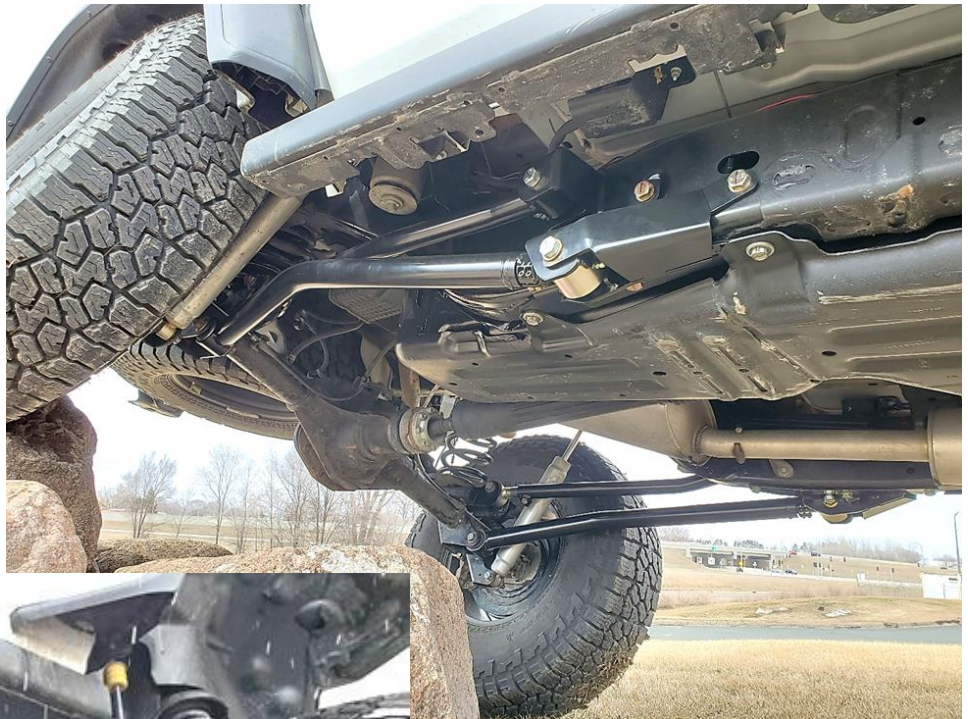



# IRON ROCK OFF ROAD

2-5/8" IRO Flex End 16mm Bolt  
Assembly Instructions

1-877-919-JEEP www.ironrockoffroad.com

*This flex end uses a larger 16mm through bolt. Do not confuse it with HK #127*

## Before you begin:

- o Read and understand installation instructions.
- o Contact Iron Rock Off Road with any questions before, during, or after installation.
- o **Ensure that all parts are present and in good condition per attached shipping checklist!**
- o Have these tools handy:
  - o 5/32" Allen head socket
  - o 3/8" open end wrench
  - o Inch-lb. torque wrench
  - o Multipurpose grease/grease gun

## Parts Checklist:

- Outer housing, weld on (may already be attached to your existing control arm)

### #233 - 2-5/8" IRO Flex End (6 bolt)

- 2-5/8" flex end race 91118 (2)
- Thrust washer 91119 (2)
- 2-5/8" flex end ball 16mm 91242 (1)
- #10-32 nylock nut (7)
- #10-32 x 1-3/4" socket head cap screw (6)
- 90° 1/4"-28 grease zerk fitting (1)

## Assembly:

1. Insert two #10-32 socket head cap screws into one thrust washer and one plastic race. Spherical bore of race facing away from thrust washer. (Figure 1)
2. Install this small assembly into the flex end housing. The races are a light press fit, use a wide punch and hammer to assist you if needed.
3. Apply a thin coating of multi-purpose grease to the mating surfaces of the ball and both races.
4. Place the ball in the race (inside the flex end). The ball should perfectly fit the contour of the race. (Figure 2)
5. Insert the other race onto the ball so that the spherical bore is contacting the ball. Once again, the races are a light press fit, use a hammer and wide punch if needed. (The two screws should be through one washer and both races at this point)
6. Insert the second thrust washer on top of the flex end housing, sliding the bolts through the holes. (Figure 3)
7. Start nylock nuts on the two bolts that are in the flex end assembly. Hold the nut and turn the bolt.
8. Insert the remaining four cap screws through the remaining holes and install nuts. (Figure 4)
9. Snug up all of the bolts fairly tight.
10. Torque bolts evenly, starting at one bolt and continuing using a crisscross pattern. Torque all six bolts to 70 in-lbs., then to 85 in-lbs.
11. Install 90° grease zerk fitting so that it is easily accessed in the vehicle.
12. Grease flex end until grease comes out of the races around the ball.
13. Re-torque bolts to 85 in-lbs. after 5 minutes.



Figure 1

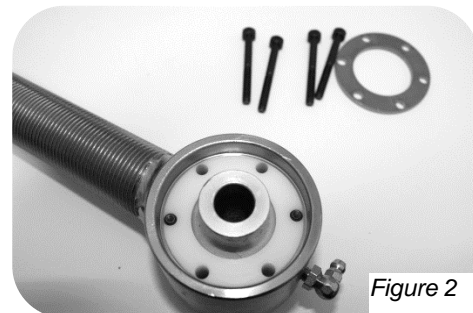

Figure 2



*\*Reference Only\* Complete joint shown fully assembled without housing*

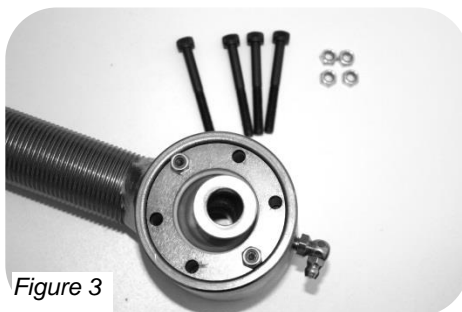

Figure 3

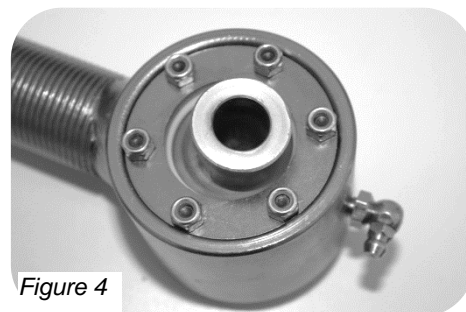

Figure 4



# IRON ROCK OFF ROAD

2-3/8" IRO Flex End (8 bolt)  
**Assembly Instructions**  
 I-877-919-JEEP www.ironrockoffroad.com

## Before you begin:

- o Read and understand installation instructions.
- o Contact Iron Rock Off Road with any questions before, during, or after installation.
- o **Ensure that all parts are present and in good condition per attached shipping checklist!**
- o Have these tools handy:
  - o 9/64" Allen head socket
  - o 3/8" open end wrench
  - o Inch-lb. torque wrench
  - o Multipurpose grease/grease gun

## Parts Checklist:

- Outer housing, weld on (may already be attached to your existing control arm)

### #168 - 2-3/8" IRO Flex End (8 bolt)

- Inner race 91139 (2)
- Thrust washer 91138 (2)
- Ball 91140 (1)
- #8-32 x 1-1/2" socket head cap screw (8)
- 1/4"-28 90° grease zerk fitting (1)
- 1/4"-28 straight grease zerk fitting (1)

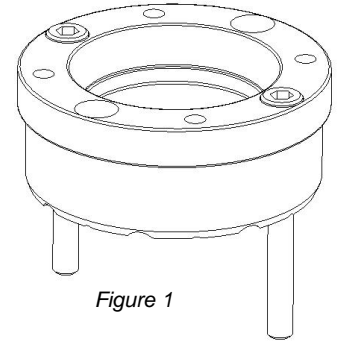
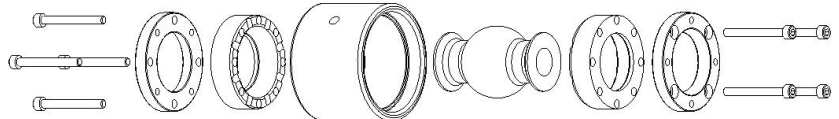
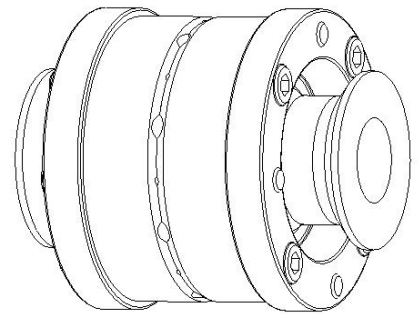

Figure 1

## Assembly:

1. Insert two #8-32 socket head cap screws into one thrust washer and one plastic race. Spherical bore of race facing away from thrust washer. (Figure 1)
2. Install this small assembly into the flex end housing. The races are a light press fit, use a wide punch and hammer to assist you if needed.
3. Apply a thin coating of multi-purpose grease to the mating surfaces of the ball and both races.
4. Place the ball in the race (inside the flex end). The ball should perfectly fit the contour of the race.
5. Insert the other race onto the ball so that the spherical bore is contacting the ball. Once again, the races are a light press fit, use a hammer and wide punch if needed. (The two screws should be through one washer and both races at this point)
6. Insert the second thrust washer on top of the flex end housing, aligning the bolts with the threaded holes.
7. Start threading the two bolts into the threaded holes of the thrust washer. Do not fully tighten at this time.
8. Insert the remaining cap screws through the remaining holes and get them started in the threaded washer.
9. Snug up all of the bolts fairly tight. Go back and forth, rechecking each bolt several times to ensure even clamping
10. Torque bolts evenly starting at one bolt using a crisscross pattern, like torquing lug nuts. Torque all eight bolts to 50 in-lbs., then to 65 in-lbs.
11. Install 90° grease zerk fitting so that it is easily accessed in the vehicle.
12. Use a grease gun to grease the flex end through the zerk fitting. This will be difficult due to the tight tolerances in the flex joint assembly.
13. Re-torque bolts to 65 in-lbs.



*\*Reference Only\* Complete joint shown fully assembled without housing*

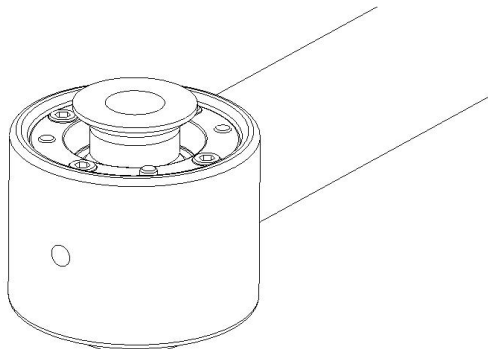



# IRON ROCK OFF ROAD

## Track Bar Flex End Assembly Instructions

1-877-919-JEEP www.ironrockoffroad.com

### Parts Checklist:

#### #122 - Track Bar Flex End Hardware - 12mm (1)

- Inner race (plastic) 91113 (2)
- End cap (steel) 91112 (2)
- Ball 91104 – M12 bolt (1)
- #5-40 x 1 1/4" Socket head cap screw (9)
- 3/32" Hex L key, high torque (hex plus) (1)

#### #254 - Track Bar Flex End Hardware - 14mm (1)

- Inner race (plastic) 91113 (2)
- End cap (steel) 91112 (2)
- Ball 91142 – M14 bolt (1)
- #5-40 x 1 1/4" Socket head cap screw (9)
- 3/32" Hex L key, high torque (hex plus) (1)



### Safety Warning:

Installation and assembly of this part requires knowledge of steering and suspension systems. Failure to precisely adhere to installation procedure may cause a part failure resulting in vehicle damage and serious injury or death. This part only fits Iron Rock Off Road track bars in good condition. Iron Rock Off Road makes no claims that this part will fit track bars from other manufacturers. Improper fitment may cause a part failure resulting in vehicle damage, serious injury, or death.

### Before you begin:

- o Read and understand installation instructions.
- o Contact Iron Rock Off Road with any questions before, during, or after installation.
- o **Ensure that all parts are present and in good condition per attached shipping checklist!**
- o Ensure that you have high strength threadlocker (such as red Loctite) and multi-purpose grease.

### Fitment:

This kit replaces the poly bushings and inner sleeve in your Iron Rock Off Road track bar. This part only fits track bars manufactured by Iron Rock Off Road after 2009 with an inside diameter of 1.510", a width of 1.250", and a radiused inside corner.

**\*\*\*To verify fitment: Remove the track bar from your vehicle, remove the poly bushings, clean the parts, and verify the following is true: \*\*\***

- The plastic races fit tight inside the inside bore.
- Both end caps fit the inside bore with just a bit of "wobble room".
- Both end caps slide in freely until the flat shoulder rests firmly against the end of the outer tube.
- The overall width of the outer tube is 1.250". This can be measured with a caliper or verified after flex end is fully assembled. Once fully assembled (bolts torqued to spec.) the shoulders of the end caps should rest firmly against the ends of the outer tube. At the same time, the ball should fit tight inside the assembly. It should require a tool (such as a screwdriver) to pivot or rotate the ball. The ball should pivot smoothly with even resistance in any position.



If any of those steps cannot be verified, please contact us to order a new track bar.

Bolt size: This bushing replacement assembly is only available to fit a 12mm & 14mm bolt at this time. Those with a 10mm fastener may wish to upgrade to 12mm hardware for more strength (drill your bracket and install a 12mm bolt).

### Assembly:

1. Verify fitment per the "Fitment" section above.
2. Insert four socket head cap screws into one end cap and one race. (Race should have spherical bore facing away from end cap.)
3. Install this small assembly into the track bar outer bushing tube. The races are a light press fit, use a wide punch and hammer to assist you if needed.
4. Apply a thin coat of multi-purpose grease to the ball and the spherical mating surface of the races. Coat both mating surfaces but leave no excess grease that would interfere with the threadlocker adhesive on the bolts.
5. Place the ball into the race inside the housing. The ball should fit the contour of the race perfectly.
6. Insert the other race on top of the ball so that the spherical bore is contacting the ball. Once again, the races are a light press fit, use a hammer and wide punch if needed. (The four screws should be through one end cap and both races at this point.)
7. Apply a generous coating of high strength threadlocker (such as red Loctite) to all 8 screws (including the ones already installed).
8. Install the second end cap, aligning the screws with the tapped holes. When completed 4 screws will be inserted from each side.
9. Insert the last four screws and tighten them all snug.
10. Torque screws in sequence using a crisscross pattern, like torquing lug nuts. Tighten all 8 screws evenly in small steps. Take your time and do not rush. Tighten all 8 screws to 20 in/lbs.



# IRON ROCK OFF ROAD

JL & JT

1-877-919-JEEP www.ironrockoffroad.com

Sway Bar Disconnect

## Parts List:

- Front Sway Bar Link, 7.5" center to center 92246 (2)
- Passenger Side Disconnect Bracket 77080 (1)
- Passenger Side Disconnect Plate 77082 (1)
- Driver Side Disconnect Plate Small 77084 (1)
- Driver Side Disconnect Plate Large 77083(1)

## #268 – Sway Bar Disconnect Bushings (1)

- Poly Bushing 94025 (4)

## #276 – JL & JT Sway Bar Disconnect Hardware (1)

- Disconnect Pin 94028 (4)
- 1/2-20 x 1" Hex Bolt, gr8 (4)
- 1/2 F436 Hard Washer (8)
- 1/4" x 1-1/4" Spring Pin (4)
- M12 x 70 Hex Bolt (1)
- M12 x 45 Hex Bolt (1)
- M12 Nylock Nut (2)

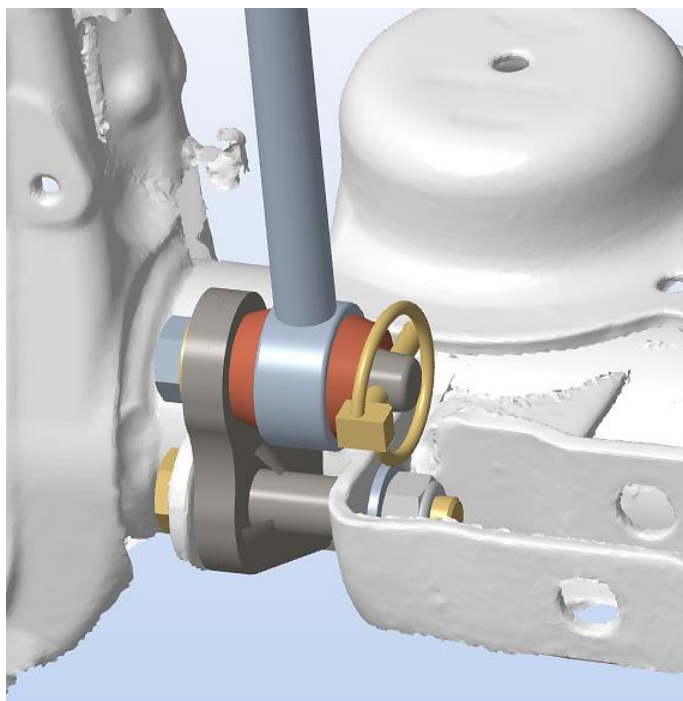
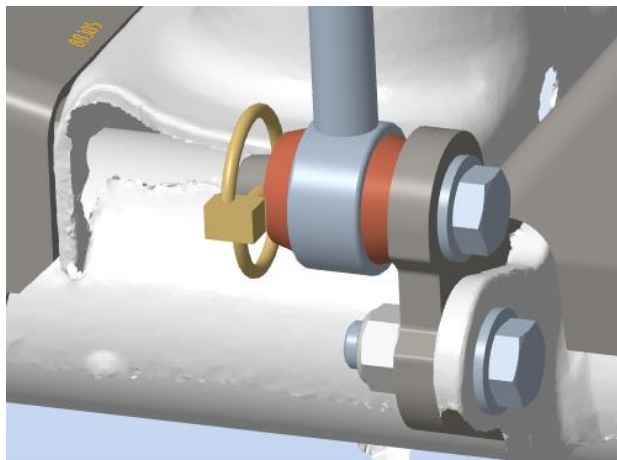
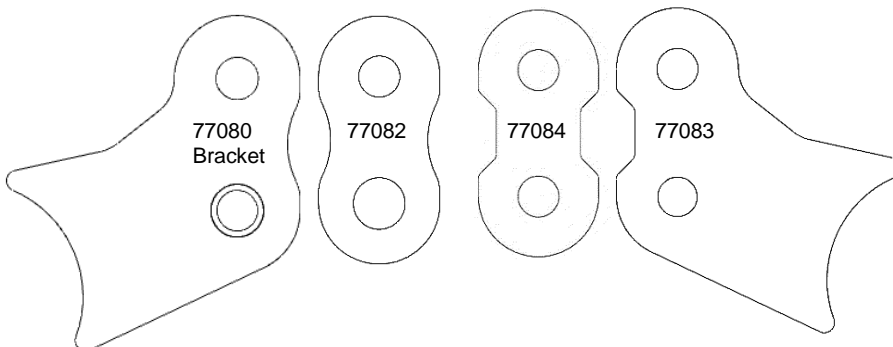

## Installation Instructions:

### Safety Warning: \*Important! Read before installation.\*

We recommend this system be installed by a qualified professional. Knowledge of suspension component function is necessary for safe installation and post installation inspections. Be sure to re-torque all suspension components after the first 100 miles of use, and frequently inspect all safety critical suspension components frequently.

### Notes:

- This kit requires Iron Rock front sway bar links from an IRO lift kit or available separately for purchase.
- Do not operate vehicle with only one side of the sway bar connected. Both sides of the sway bar must either be disconnected or both sides must be connected.

### Before you begin:

- Read all safety warnings.
- Read and understand installation instructions.
- Contact Iron Rock Off Road with any questions before, during, or after installation. 952-210-7185
- Ensure that all parts are present and in good condition using the included shipping checklist.**
- Be sure you have the following tools and supplies:
  - Floor jack and jack stands.
  - Basic hand tools (wrenches, sockets, etc.).
  - Multi-purpose grease



### **Removal of existing parts:**

1. Raise the vehicle and secure on jack stands under the front axle.
2. Remove the front tires.
3. Disconnect the front sway bar links from the axle and sway bar.
4. Remove the sleeves and bushings from the Iron Rock sway bar links.

### **Installation:**

5. Use a 1/2" drill bit to slightly enlarge the bolt hole in the sway bar. Only a very minor amount of material will be removed.
6. Install the disconnect pin on the sway bar, pin pointing out-board. Use the 1/2" x 1" bolt with a washer.

**Tip:** Before tightening determine your desired orientation for the retaining pin.

7. Hold the disconnect pin in your desired orientation and torque the bolts to 70lb-ft.

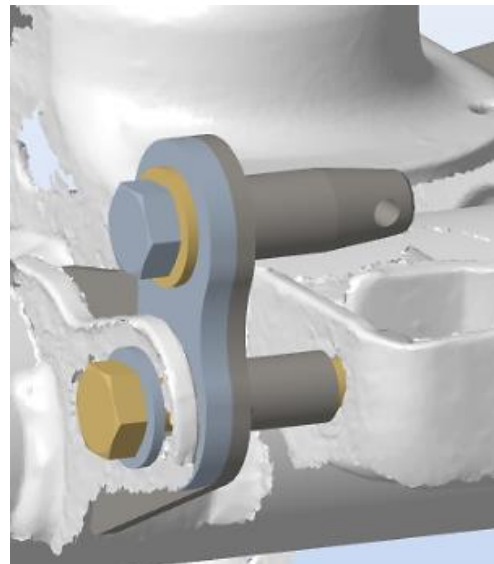
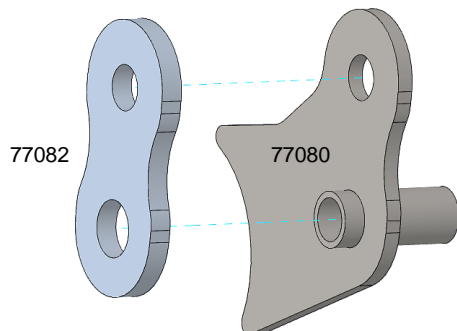

8. Align the holes and slide the plate 77082 onto the unwelded side of bracket 77080.
9. Slide the bracket assembly between the sway bar link tab and the track bar mount.
10. Install using the long M12 bolt, washers, and nylock nut.
11. Install the disconnect pin on the bracket assembly, pin pointing in-board. Use the 1/2" x 1" bolt with a washer.
12. Hold the disconnect pin in your desired orientation and torque both bolts to 70lb-ft.

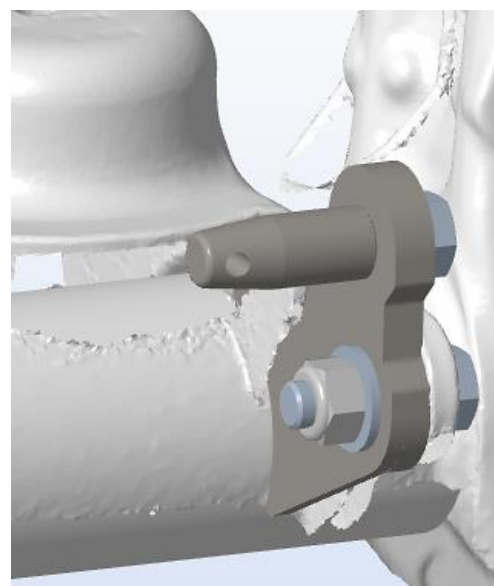
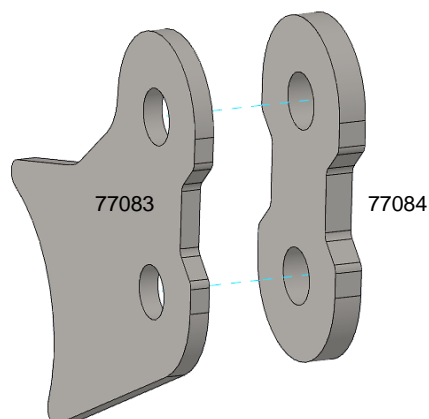

13. Align the holes in plate 77083 and plate 77084.
14. Slide the assembly between the sway bar link tab and the spring mount.
15. Install using the short M12 bolt, washers, and nylock nut.
16. Install the disconnect pin on the assembly, pin pointing in-board. Use the 1/2" x 1" bolt with a washer.
17. Hold the disconnect pin in your desired orientation and torque both bolts to 70lb-ft.
18. Install the new bushings into the sway bar links using plenty of multi-purpose grease.
19. Apply grease to the disconnect pins and slide the sway bar link onto the disconnect pins.
20. Secure the sway bar link in place using the spring pins.  
**\*NOTE:** The spring pin should take some effort to install. This is done on purpose to keep the link secure and noise free.
21. Reinstall tires and torque lug nuts to spec.
22. Lower vehicle to the ground.
23. With the vehicle back on the ground, pull the spring pins and slip the sway bar links off the disconnect pins.
24. Swing the sway bar up to its highest position.
25. Flex the suspension and steer fully left and right. Check for possible interference between the tires and sway bar.
26. Reconnect the sway bar links with the spring pins.
27. For ease of installation and best performance, re-grease the sway bar bushings periodically.

### **Final Safety Warning:**

**\*Both sides of the sway bar must be disconnected. Do not operate vehicle with only one side of the sway bar connected.**

Re-torque all fasteners after 100 miles, and frequently inspect all safety critical suspension components. It is the responsibility of the installer to ensure all fasteners are properly tightened after installation and to ensure the owner knows his/her ongoing responsibility. It is the responsibility of the owner of the vehicle to be sure all safety critical components are inspected frequently, especially after off road or other demanding use.