

IRON ROCK OFF ROAD

Stackable Bump Stop Instructions

I-877-919-JEEP www.ironrockoffroad.com

Parts List:

- Instructions
- Iron Rock Off Road logo decal 10001 (1)
- 1 Inch Top Bump Stop 88271 (2)
- ½ Inch Bump Stop Spacer 88272 (2)
- 1 Inch Bump Stop Spacer 88273 (2)
- 1½ Inch Bump Stop Spacer 88274 (2)

#192 – Bump Stop Hardware (1)

- 7/16 x 1 ½" hex bolt, gr5 (2)
- 7/16 x 2 ½" hex bolt, gr5 (2)
- 7/16 x 3 ½" hex bolt, gr5 (2)
- 7/16 x 4 ½" hex bolt, gr5 (2)
- 7/16 flag nut 80063 (2)

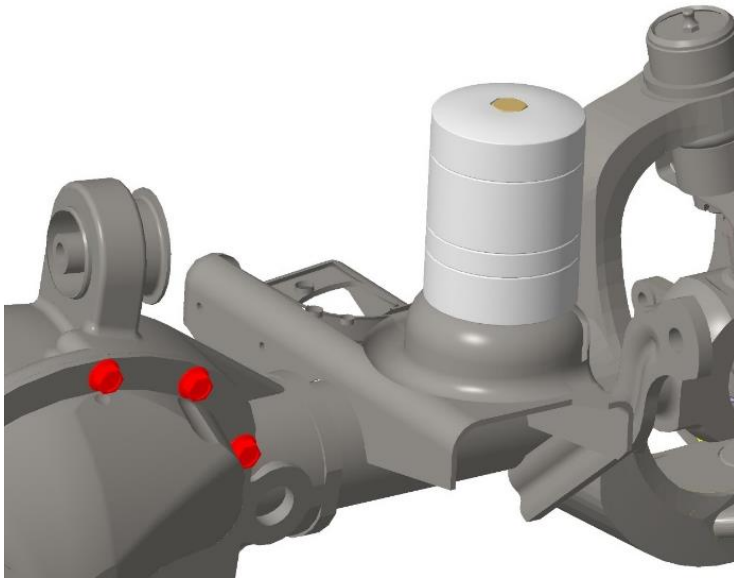
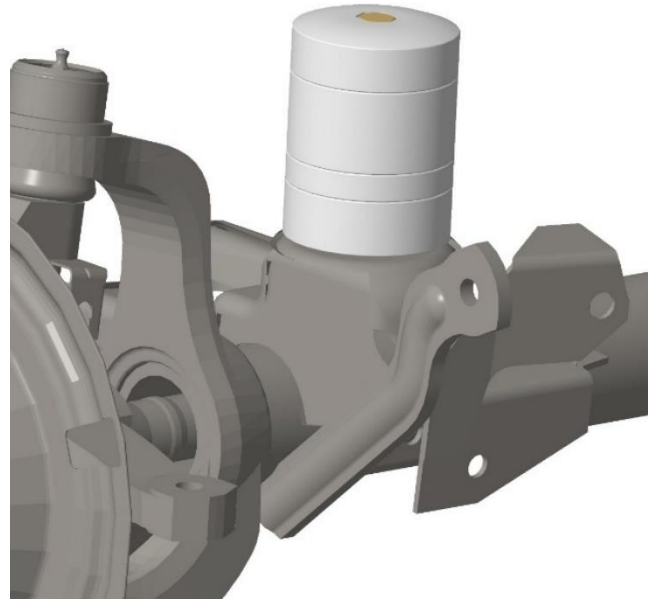

Installation Instructions:

Safety Warning: *Important! Read before installation. *****

We recommend this system be installed by a qualified professional. Knowledge of suspension component function is necessary for safe installation and post installation inspections. Be sure to re-torque all suspension components after the first 100 miles of use, and frequently inspect all safety critical suspension components.

Before you begin:

- Read all safety warnings.
- Read and understand installation instructions.
- Contact Iron Rock Off Road with any questions before, during, or after installation.
- Ensure that all parts are present and in good condition using the included shipping checklist.**
- Be sure you have the following tools and supplies:
 - Floor jack and jack stands.
 - Basic hand tools (wrenches, sockets, etc.).
 - Tape measure
 - Hand drill and 7/16" drill bit
 - Center punch
 - Thread Locker – Medium strength (blue)

Bump Stop Height	Bolt Length
4.0 Inch	4.5"
3.5 Inch	
3.0 Inch	3.5"
2.5 Inch	
2.0 Inch	2.5"
1.5 Inch	
1.0 Inch	1.5"

Removal of existing parts:

1. Raise the vehicle and secure on jack stands under the frame.
2. Remove the tires.
3. Disconnect the sway bar links from the axle.
4. Disconnect the shocks from the axle.
5. Remove the springs.

Front Axle Installation – XJ, ZJ, TJ, JK:

6. Determine your desired bump stop height.
7. Stack bump stop top and spacers to achieve desired height and align them with the correct bolt length.
8. Mark the center of your lower spring mount with a center punch then drill a 7/16 hole.
9. Position the flag nut under the spring mount, aligning the nut with the drilled hole.
10. **XJ, ZJ, TJ Only:** The track bar side requires the flag nut be bent slightly more (approx. 80 degrees)
11. **XJ, ZJ, TJ Only:** Install the flag nut through the slot in the bottom of the track bar mount.
12. Apply a small amount of medium strength thread locker to bump stop bolt and install into flag nut.
13. Ensure the bolt hex engages the hex in the top bump stop.
14. Spin the bump stop stack until tight.

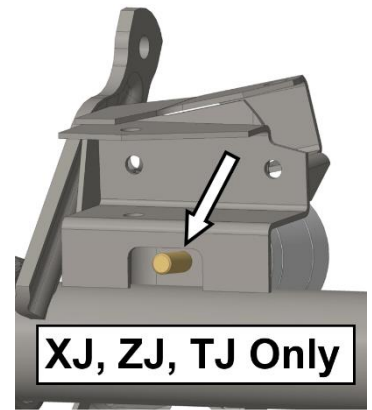

Final Checks and Reinstallation:

15. Reconnect the shocks to the axle.
16. Temporarily install tires.
17. With the shocks connected and springs out use a jack to check suspension articulation left and right, as well as both sides fully compressed.
**On front axles: turn the wheels left and right while suspension is articulated.
**If interference between the tires and body is found adjust bump stop height or trim body work accordingly.
18. Reinstall springs.
19. Reconnect the sway bar links to the axle.
20. Reinstall tires and torque lug nuts to spec.
21. Lower vehicle.

Final Safety Warning:

* Re-torque all fasteners after 100 miles, and frequently inspect all safety critical suspension components. It is the responsibility of the installer to ensure all fasteners are properly tightened after installation and to ensure the owner knows his/her ongoing responsibility. It is the responsibility of the owner of the vehicle to be sure all safety critical components are inspected frequently, especially after off road or other demanding use.

