

# Iron Rock Off Road

## Dana 30 Over Axle Truss

### Installation Instructions:

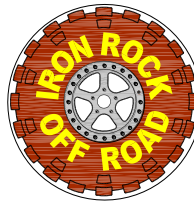

**Iron Rock Off Road, Inc.**

952-210-7185

Website: [www.ironrockoffroad.com](http://www.ironrockoffroad.com)

E-mail: [Contactus@ironrockoffroad.com](mailto:Contactus@ironrockoffroad.com)

Fits: 97-06 Jeep Wrangler TJ, 84-01 Jeep Cherokee XJ, and 95-98 Jeep Grand Cherokee ZJ. Fit's only Dana 30 front axle (does not fit Rubicon model Wranglers). See step 1 for critical fitment information.

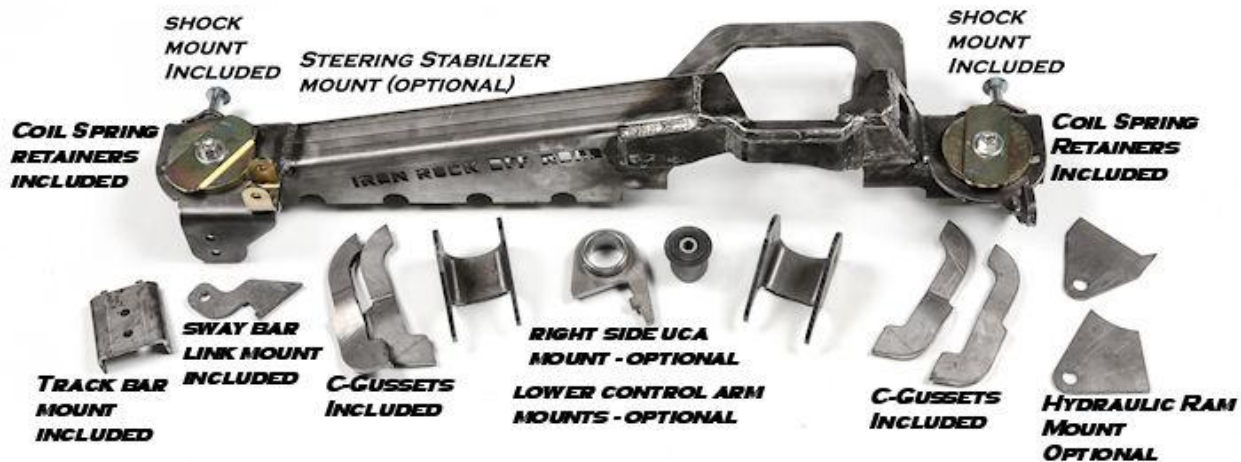

#### **Before you begin:**

1. Fitment requirements:
  - a. For optimal performance these modifications have been made compared to OEM parts: Make any necessary accommodations.
    - i. Coil spring pads raised 1" and moved back 1/2".
    - ii. Track bar mount moved back 1/2" with the option of OEM height or raised 1 1/2".
    - iii. Sway bar link mounts raised 1/2" and moved back 1".
    - iv. Shock mounts raised 5/8" and moved outward 1" per side.
  - b. Optional passenger side upper control arm mount may require adjustable upper control arms.
  - c. Works with all Iron Rock Off Road suspension components.
  - d. If using products from other manufacturers verify fitment before installation.
  - e. This product has not been tested at OEM suspension height and likely will not work. We recommend 3" lift or more.
  - f. It is recommended to replace axle seals after installation due to welding heat.
2. Read and understand all installation instructions.
3. If you have any questions before, during, or after installation contact Iron Rock Off Road (see contact information above).
4. **Ensure that all parts are present and in good condition.**

- 88034 Truss assembly (1)
- 88025 C-Gusset front right (2)
- 88026 C-Gusset front left (2)
- 88043 Inner track bar mount (1)
- 88045 Right SBL mount (1)
- 99054 Lower coil spring retainer (4)
- 99059 Upper coil spring retainer (2)

#### **Hardware Kit 69**

- 7/16 x 2 1/2 hex bolt, gr8 (1)
- M12 x 70mm hex bolt, cl10.9 (4)
- 7/16 hex nut, gr8 (1)
- 1/2 nylock nut, gr8 (2)
- M12 hex nut, cl10.9 (2)
- M12 nylock nut, cl10.9 (2)
- 7/16 USS washer (5)
- 1/2 USS washer (2)
- 12mm shock sleeve (2)

#### **Prepare the parts for installation:**

5. Remove the axle assembly from the vehicle.
6. Remove any remaining steering or suspension components from the axle assembly.
7. Check housing and tubes for straightness: Using an angle finder, with the pinion horizontal, check the slope along the entire length of each tube. Any variance of 1/4 degree or more must be straightened or the housing replaced. Be sure to remove any rust or dirt from under the angle finder. Perform the same check with the pinion vertical.

8. Cut off all suspension brackets except lower control arm mounts and driver's side upper control arm mount. A plasma cutter or oxy-acetylene torch work best for this. Be careful not to cut into the tubes at all.
9. Grind away any remaining bracket residue. A 4 1/2" angle grinder with a flap wheel works well for this.
10. Clean the differential housing where it meets the tubes. A 4 1/2" angle grinder with a wire wheel works well for this. Must be extremely clean.



**Install the Truss:**

11. Weld the diff. housing to the tubes: On one side preheat the diff housing where it meets the tube to approx. 425 degrees. Weld approx. 1 1/2" then about 1 1/2" on the opposite side of the same tube, continue stitch welding until completely welded.
12. Cover with a welding blanket to slow the cooling process (this helps prevent cracks).
13. Repeat for other axle tube starting with the preheating.
14. Repeat step 7 to verify that housing and tubes are still straight.
15. Set the truss assembly onto the axle assembly.
16. Rotate the truss so that the front surface of the truss (over the diff. housing) is 3/4" in front of the diff cover mounting surface (not the diff cover itself). See Photo.
17. Center the truss side to side.
18. The truss should extend down to nearly the center of the axle tube at front and rear.
19. Tack weld the truss to the axle assembly at several locations along the truss.
20. Weld the truss to the axle tubes by alternating 2" welds on opposite sides of the axle assembly. Allow a short cooling off period between welds. Ensure good weld penetration but try to minimize the amount of heat and the heat affected zone.
21. After the truss is completely welded, insert the inner track bar mount using the alignment slots on the pass side coil spring pad. Tack weld in place. See photo.
22. Fully weld track bar mount.
23. Insert passenger side sway bar link mount using alignment slot and tab. See photo.
24. Ensure straightness and tack weld in place.
25. Fully weld.
26. Remove brakes, wheel bearings, knuckles, and upper ball joints.
27. Thoroughly clean axle C surfaces where they meet the C gussets.
28. Position "C" gussets so that it sits ON TOP of steering stop. See photo. Small gaps are common.
29. Tack weld gusset into place using 4 tack welds.
30. Fully weld C gussets by alternating 2" welds on opposite ends. Allow a short cooling off period between welds. Ensure good weld penetration, but try to minimize the amount of heat and heat affected zone.
31. Cover with welding blanket to ensure a slow, even cooling process.
32. Remove any weld spatter and prepare axle assembly for paint.
33. Repeat step 7 to verify that housing and tubes are still straight. Axle must be completely cool for this measurement.
34. Replace upper ball joints and install new axle seals.
35. Paint axle assembly.

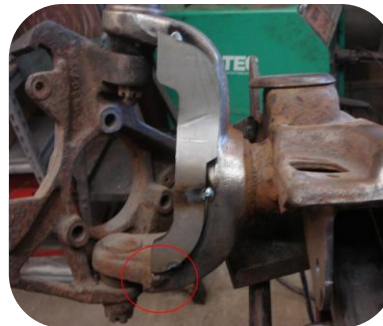

**Install the much improved axle assembly:**

36. Install axle assembly back into the Jeep.

**\*\*\*!!! Important Safety Warning!!!!\*\*\***

Ensure that C-Gussets do not contact brake calipers at full lock steering. Verify clearance around all components throughout the entire suspension and steering cycle.

