

# IRON ROCK OFF ROAD

**XJ 3" Premium Short Arm Lift Kit Installation Instructions**

I-877-919-JEEP www.ironrockoffroad.com

XJ 84-01 Jeep Cherokee

## Parts Checklist:

- Iron Rock logo decal 10001 (2)
- Ironrockoffroad.com decal (1)
- XJ 3" front spring 96016 (1 pair)
- XJ 1" transfer case drop spacer 90165 (2)
- XJ boomerang shackle 91110 (2)
- Adjustable front upper control arm 99068B (2)
  - Front UCA Threaded Male End 99067 (2)
    - 1-14 Jam Nut (2)
    - Bushing installed (2)
- #274 - XJ Rear Shock Spacer Hardware (1)**
  - Spacer 99170 (2)
- #11 Front Brake Line Relocation Hardware (1)**
  - 1/4 x 1" Self drilling sheet metal screw (2)
- #14 - XJ 1.75" T-case Drop/ Rear Brake Line Bracket (1)**
  - 3/8 USS Flat Washer (4)
  - 5/16 USS Flat Washer (2)
  - 5/16-18 gr8 hex nut (1)
  - 5/16-18 x 1" gr8 hex bolt (1)
  - M10 x 70 hex bolt cl10.9 (4)
  - Rear brake line drop bracket 91089 (1)
- #134 IRO Shackle Hardware (1)**
  - IRO shackle bushing M02247 (4)
  - IRO bushing sleeve 91100 (2)
  - 1/4"-28straight grease zerk (2)

## Add-A-Leaf Box: 10455 (1)

- IRO Add-a-Leaf 96013 (2 Leafs)



- #136 Add-a-leaf Hardware (1)**
  - Upper leaf clamp 96021 (4)
  - Lower leaf clamp 96022 (4)
  - 5/16-24 x 4 Center pin (2)
  - 5/16-24 hex nut (2)

## ~Standard Front Sway Bar Links~

- Front sway bar links 8.75" center to center 92145 (2)
- #10 - Front Sway Bar Links Hardware (1)**
  - 3/4" I.D. hourglass shock bushing 94025 (4)
  - 12mm I.D. sway bar bolt sleeve 92038 (4)
  - 12mm x 70mm class 10.9 hex bolt (2)
  - 12mm class 8.8 hex nut (2)
  - 1/2" x 1 1/2" grade 8 hex bolt (2)
  - 1/2" grade 8 lock washer (2)
  - 1/2" grade 8 hex nut (2)
  - Sway bar link U-bracket 99000 (2)



## ~Optional Front Sway Bar Disconnect Upgrade~

- Front sway bar links 8.75" center to center 92145 (2)
- #268 - Sway Bar Disconnect Bushings (1)**
  - Poly Bushing 94025 (4)
- #287 - XJ Sway Bar Disconnect Hardware (1)**
  - Disconnect Pin 94028 (2)
  - 1/2-20 x 1" Hex Bolt, gr8 (2)
  - 1/2 F436 Hard Washer (2)
  - 1/4" x 1-1/4" Spring Lynch Pin (2)
  - 12mm bolt sleeve 92038 (2)
  - M12 x 70 cl10.9 hex bolt (2)
  - M12 cl10.9 hex nut (2)
  - 1/2 x 1 1/2" gr8 hex bolt (2)
  - 1/2 gr8 lock washer (2)
  - 1/2 gr8 hex nut (2)
  - U-Bracket 99000 (2)



## U-Bolt set - specific to customer vehicle:

- Optional: Ford 8.8 - 91093 (4 U-bolts)**
  - 9/16-20 high nut (8)
  - 9/16 hardened flat washer (8)
- Optional: Dana 35/44 - 91094 (4 U-bolts)**
  - 1/2-20 high nut (8)
  - 1/2 hardened flat washer (8)
- Optional: Chrysler 8.25 - 91095 (4 U-bolts)**
  - 1/2-20 high nut (8)
  - 1/2 hardened fat washer (8)

## ~Optional Full OEM Leaf Pack~ (in addition) OEM Leaf Spring Kit Box: 10494 (1)

- XJ OEM leaf spring 4886186AA (2)



- Front Bushing 52000503 (2)
- Rear Bushing 52000504 (2)

## Standard Rubber Bushing Lower Control Arms (Front)

- Adjustable bent lower control arm, bushing installed 99169B (2)
- LCA Threaded Male End, bushing installed 99070 (2)

## #65 - Adjustable LCA Clamping Hardware (1)

- 1/4"-28 x 1-1/8" socket head cap screw (4)
- 1/4"-28 hex nut, gr8 (4)



## Optional Flex Joint Lower Control Arms (Front)

- Adjustable bent lower control arm, bushing installed 99169B (2)
- LCA Threaded Male End 92186 (2)

## #65 - Adjustable LCA Clamping Hardware (1)

- 1/4"-28 x 1-1/8" socket head cap screw (4)
- 1/4"-28 hex nut, gr8 (4)

## #127 - 2 5/8" 6 Bolt IRO Flex End Hardware (2)

- Inner race 91118 (2)
- Thrust washer 91119 (2)
- 2-5/8" Flex End Ball 91117 (1)
- 10-32 x 1-3/4" Socket Head Cap Screw (6)
- 10-32 Nylock Nut (6)
- 1/4"-28 90° Grease zerk Fitting (1)

- Double Shear Track Bar Bracket 91015 (1)
- Double adjustable track bar 92305 (1)
- Double adjustable track bar male end 92297 (1)
- Double adjuster, track bar 91235 (1)



## ~Standard Front Track Bar~

## #277 - XJ/ZJ Double Adjustable Track Bar Hardware (1)

- Track bar bushing half 80014 (4)
- 12mm track bar bushing sleeve 92035 (1)
- 7/16" I.D. track bar bushing sleeve 92036 (1)
- Track bar clamp 92303 (2)
- M12-1.75 x 80 hex bolt (2)
- M12-1.75 hex nut (2)
- 7/16" x 2-1/2" hex bolt, gr8 (1)
- 7/16" Track Bar Flag Nut 91230 (1)
- 7/16" USS flat washer (5)

**-Optional Front Track Bar-**

**#122 - Track Bar Flex End Hardware - 12mm (1)**

- Inner race (plastic) 91113 (2)
- End cap (steel) 91112 (2)
- Ball 91104 – M12 bolt (1)
- #5-40 x 1 1/4" Socket head cap screw (9)
- 3/32" Hex L key, high torque (hex plus) (1)

**#277 – XJ/ZJ Double Adjustable Track Bar Hardware (1)**

- Track bar bushing half 80014 (4)
- 12mm track bar bushing sleeve 92035 (1)
- 7/16" I.D. track bar bushing sleeve 92036 (1)
- Track bar clamp 92303 (2)
- M12-1.75 x 80 hex bolt (2)
- M12-1.75 hex nut (2)
- 7/16" x 2-1/2" hex bolt, gr8 (1)
- 7/16" Track Bar Flag Nut 91230 (1)
- 7/16" USS flat washer (5)

**Shocks:**

**Trail Tamer HD Hydro (Standard)**

- Front Shock 79000 (2)
- Rear Shock 79003 (2)

**Doetsch Upgrade (Optional)**

- Front shock DT 8350 (2)
- Rear shock DT 8265 (2)

**#15 - Shock Hardware (1)**

- 2.5" long front barpin 403872 (2)
- 2.75" long rear barpin 404127 (2)

**Bilstein Upgrade (Optional)**

- Front Shock 33-230337 (2)
- Rear Shock 33-185606(2)

**#15 - Shock Hardware (1)**

- Front barpin 2.5" 403872 (2)
- Rear barpin 2.75" 404127 (2)

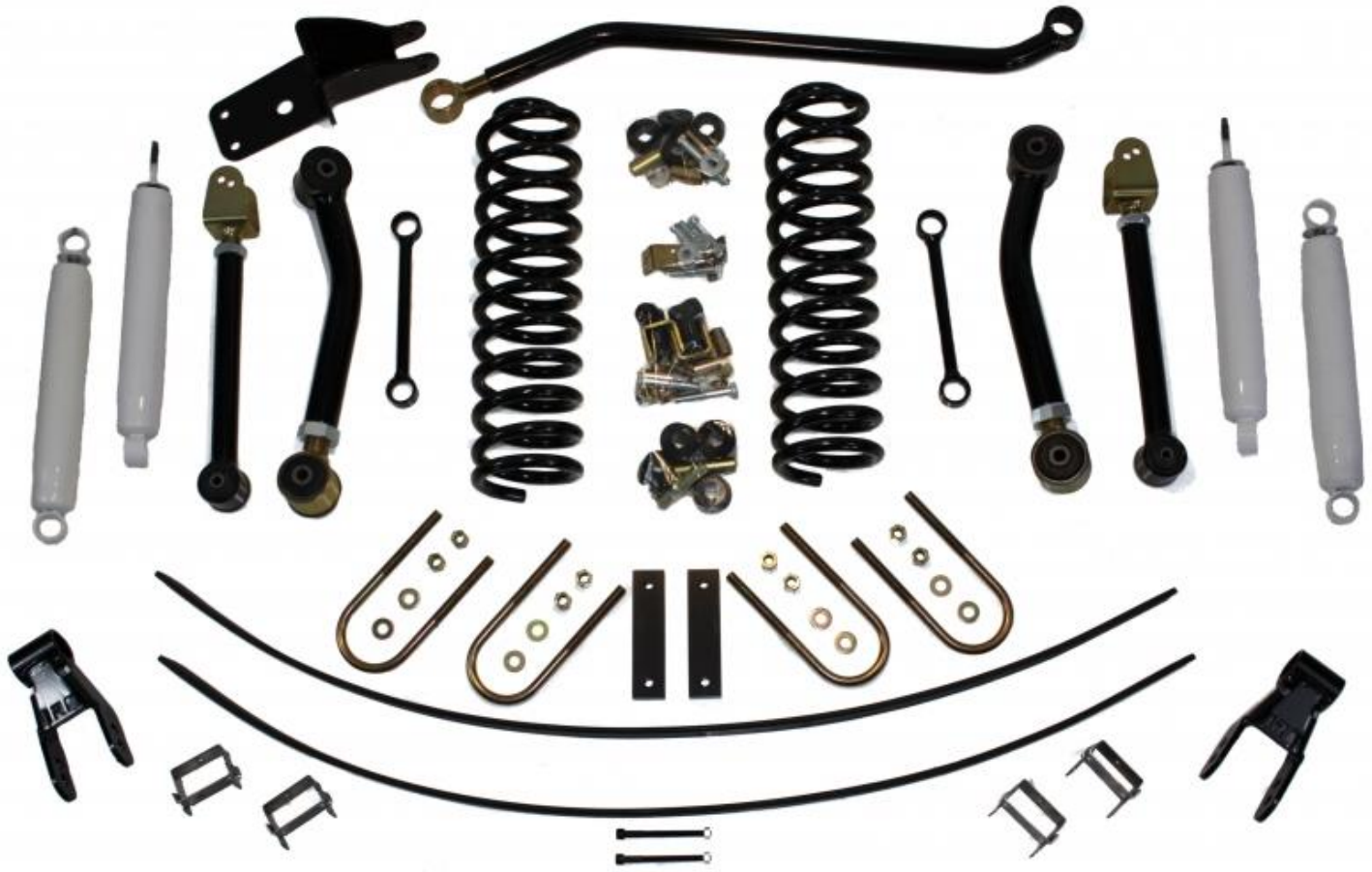

# Installation Instructions

## Safety Warning:

Installing a suspension lift kit raises the center of gravity of the vehicle. This increases the possibility of a rollover accident. Avoid sudden maneuvers at high speed and avoid all situations where a side rollover may occur. In addition, larger tires decrease braking performance, please drive accordingly. We recommend a tire and wheel combination that makes the vehicle's track width wider (wheels with less backspacing). This will lower the center of gravity and add stability. We also recommend that this system be installed by a qualified professional. Knowledge of suspension component function is necessary for safe installation and post installation inspections. Be sure to re-torque all suspension components after the first 100 miles of use, and frequently inspect all safety critical suspension components.

## Before you begin:

- Read all safety warnings.
- Read and understand installation instructions.
- Check all steering and suspension components for wear and replace as needed.
- Contact Iron Rock Off Road customer service with any questions before, during, or after installation.
- Ensure that all parts are present and in good condition using the included parts checklist.
- Be sure you have the following tools and supplies:
  - Floor jack and jack stands.
  - Basic hand tools
  - Multi-purpose grease (all poly bushings should be greased before installation)
  - Anti-seize compound.
  - Optional: This is a great time to replace your axle side upper control arm bushings with IRO flex ends.

## Front suspension:

1. Lift front of vehicle and support with tall jack stands under the unibody frame.  
**\*Tip: break lug nuts loose before lifting vehicle.**
2. Ensure that vehicle is safely supported.
3. Remove front tires.
4. Remove front shocks.
5. Remove front sway bar links.
6. Remove track bar bolt at axle end only (do not loosen the "tie rod end" at the uniframe).
7. Remove track bar bracket from the uniframe, taking the track bar with it.
8. Loosen all upper and lower control arm bolts (remove nuts but leave bolts for now).
9. Place a floor jack under the driver's side of front axle for support (do not lift vehicle).
10. Remove the coil spring clamps (at the axle).
11. Remove lower control arms.
12. Remove coil springs.
13. Install new coil springs, be sure to align the end of the spring to the coil spring bucket on the axle. Do not install coil spring clamps at this time.
14. Locate lower control arms with male threaded ends and **HK #65**.
15. Apply a thorough coating of anti-seize compound to male threads and thread male end into female end. Adjust length to 16.25" center to center. Install clamping bolts loosely.
16. Install lower control arms into the Jeep. Bend at axle end hanging down to clear shock mount at full droop. Re-use original fasteners. Do not tighten nuts at this time.
17. Ensure male ends are parallel with control arm mounts then torque lower control arm clamping bolts to **140 in-lb**. Be sure to go back and forth between both bolts several times to ensure even clamping.
18. Locate upper control arms, male threaded ends, and jam nuts. Thoroughly coat male threads with anti-seize compound. Install jam nuts and threaded male end into female end. Adjust length to 15.25" center to center at the inner hole.
19. Remove upper control arms from the Jeep and install new ones using the inner (shorter length) hole at the axle side. Re-use original fasteners. Do not tighten nuts at this time.
20. Install new front shocks using provided bolts, washers, and nuts. Tighten upper stud mount nuts just enough to slightly compress the bushings. Over compressing these bushings will result in damage to the bushings and premature bushing failure.
21. Locate track bar, track bar male threaded end, track bar bracket, double adjuster, and **HK #277**. Install clamps onto the double adjuster.  
**\*\*If you upgraded to the Premium Track Bar refer to the instructions at the end of this document. Install flex joint into frame end of track bar.**
22. Apply anti-seize to all the threads then thread the track bar and male end into the double adjuster. Ensure the ends are equally threaded into the double adjuster then adjust the length to 33-1/4" center to center as a starting point.
23. Apply multi-purpose grease to both poly bushings and both inner bushing sleeves. Install bushings then sleeves into the track bar. The sleeve with the larger hole goes into frame side. (Longer end)



24. Install the track bar bracket onto the unibody with the factory bolts. Loosely attach the bracket with the upper two bolts, then align the lower bolt mounting holes. Install the lower mounting bolts and torque all track bar bracket hardware to 92 ft-lb.
25. **\*\*\*NOTE:** If the unibody is rusty, the seam behind the factory bracket may have swelled making installation of the lower mounting bolts difficult. Using a ratchet strap to pull the bracket to align the holes or smoothing the seam with a hammer is recommended.
26. Install track bar with short end at axle. Use new 7/16 x 2-1/2 bolt, washer, and flag nut at axle side. Torque to 74 ft-lb. M12 x 80 bolt, nut, and washers at uniframe side. Torque to 80 ft-lb. Use steering wheel or a ratchet strap to help line up the holes.
27. Locate front sway bar links (8.75" center to center), 2 u-brackets, and **HK #10**. If you upgraded to IRO Sway Bar Disconnect system, refer to the instructions at the end of this document.

28. Install sway bar link u-brackets to the sway bar using 1/2 x 1 1/2" grade 8 hex bolts, lock washers, and nuts. Brackets mount to the bottom of the sway bar with the bolt facing up and the lock washer and nut on top of the sway bar. Align brackets with offset holes pushing the brackets toward the outside of the vehicle. Torque nuts to 80 ft-lb.
29. Lubricate sway bar link bushings and bushing sleeves with multi-purpose grease and install into sway bar links.
30. Install sway bar links passenger side first using provided M12 x 70mm hex bolt and nut through the u-bracket with the nuts toward the outside of the vehicle, and the original bolt, nut, and washer at the axle. Torque all nuts to 78 ft-lb.
31. Locate **HK #11**.
32. On one side, remove the bolt that holds the brake hose to the unibody.
33. Any rusted, worn, cracked, or damaged rubber or steel brake line should be replaced.
34. Pull brake line down as far as possible without over-stressing or causing a kink in the line. \*Note: Your brake line may appear different from the photo. Do not pull too far and damage the brake line.
35. Using two adjustable wrenches bend brake line bracket mounting surface so brake line points outward toward the brake caliper. See photo.
36. Mark location and drill a 1/4" hole for the brake line locating tab.
37. Fasten brake line to unibody using provided self-drilling sheet metal screw.
38. Repeat for other side.
39. Install front tires.
40. Raise vehicle from jack stands and place jack stands under the axle.
41. Install coil spring clamps.
42. With the vehicle's weight on the suspension, torque upper control nuts to 60 ft-lb.
43. Torque lower control arm nuts to 120 ft-lb.
44. Tighten all jam nuts very tight.
45. Torque lug nuts to spec.
46. Torque any other loose bolts to spec.



### **Rear Suspension:**

47. Lift rear of vehicle and support with tall jack stands under the unibody frame.  
**\*Tip: break lug nuts loose before lifting vehicle.**
48. Ensure that the vehicle is safely supported.
49. Remove rear tires.
50. Remove rear shocks.
51. Allow suspension to droop as much as possible.
52. Remove retaining clip from rear brake line at the unibody.
53. Push the brake line forward until it can be pulled down out of the bracket.
54. Install rear brake line bracket using 5/16 x 1" bolt, nut, and washers from **HK #14**. Orient the brake line down and back.
55. Gently bend the steel brake line into its new location in the bracket. Be very careful to not create a crack or a kink. Any rusted, worn, cracked, or damaged rubber or steel brake line should be replaced.
56. Install brake line retaining clip.
57. Remove leaf spring shackles.
58. Locate new leaf spring shackles and **HK #134**.
59. Apply multi-purpose grease to both mating parts then insert poly bushings. Grease both parts and then install inner bushing sleeves.
60. Install shackles onto the unibody side with the IRO text facing the rear. Re-use existing bolts.

### **If replacing leaf springs:**

61. Starting with the driver's side: place a floor jack under the driver's side of the rear axle for support (do not lift vehicle).
62. Remove leaf spring bolts at unibody and shackle.
63. Remove the U-bolts.
64. Allow axle to droop and remove leaf spring.
65. Install new leaf springs. The thicker portion of the spring goes forward.
66. Install front bolt and rear bolts but do not tighten yet.

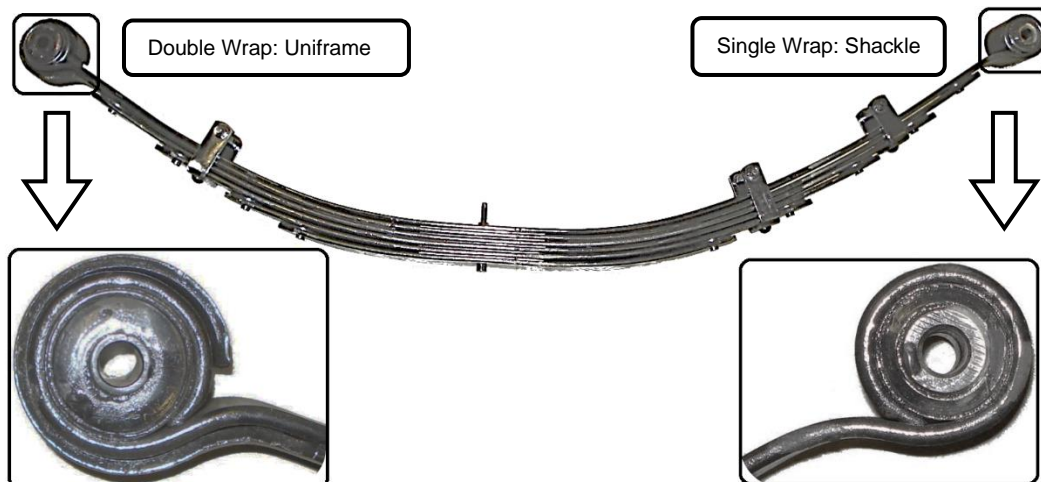

67. Clean any debris from axle seating surfaces.
68. Raise the axle up to the leaf spring, make sure the center pin drops into the axle and the axle seats flat against the leaf spring. Install U-bolts.
69. With the vehicles weight on the suspension, torque U-bolts to 90 ft-lb. and re-torque after 100 miles.
70. Repeat for passenger side.

### **Add-a-leaf kit:**

71. Starting with the driver's side, remove U-bolts.
72. Allow axle to droop and remove leaf spring clamps and center pin to take apart the leaf spring pack. Note orientation of leaves.
73. Install the new highly arched leaf in the spring pack (directly under main leaf in the #2 spot) with the long end of leaf towards the rear of the vehicle. Use a c-clamp or two to help install the new center pin.
74. Tighten leaf spring centering pin.
75. Use a c-clamp or two to help install new leaf spring clamps.
76. Clean any debris from axle seating surfaces.
77. Raise the axle up to the leaf spring, make sure the center pin drops into the axle and the axle seats flat against the leaf spring. Install U-bolts and torque to 90 ft-lb. Be sure to re-torque U-bolts after first 100 miles of use.
78. Repeat for passenger side.
79. Grease lower shock studs, install spacer from **HK #274** on lower rear shock stud then install rear shocks with shock shafts facing up. Torque lower bolts to 46 ft-lbs.
80. Apply anti-seize to upper bolts and install rear shocks using original hardware. Torque upper shock barpin bolts to 17 ft-lbs.
81. Install rear tires.
82. Lower vehicle from jack stands.
83. With the vehicle on the ground, torque any loose bolts to spec. including leaf spring bolts and lug nuts.

### **Transfer Case Drop Kit:**

84. Place a floor jack under the driver's side of transfer case crossmember for support.
85. Remove bolt and nut that hold the t-case crossmember to the unibody.
86. Lower t-case crossmember away from unibody and remove threaded stud from unibody. If you do not have a stud puller, you can install 2 nuts and tighten one against the other then remove using a box end wrench on the inner nut.
87. Install spacer using new bolts and washers from **HK #14**. Torque to spec.
88. Repeat for passenger side.

### **Adjustments and Safety Inspection:**

89. Check all components for clearance for suspension to fully cycle up and down and wheels to turn lock to lock. Pay special attention to brake line length and location of all brake lines, axle vent hoses, and ABS wires. Reposition as needed.
90. Go for a very short test drive then check track bar adjustment. Measure from top of the tire to the uniframe on each side and adjust until both measurements are equal.
91. Ensure front axle is centered. Orient track bar clamps to not interfere with any other components. Tighten track bar clamps to 60 ft-lbs. A professional front end alignment is required after installation. Your toe-in will be affected and may cause unpredictable steering and accelerated tire wear.  
Recommended caster setting: +3.75 to +6.0 (+4.5 degrees is recommended unless a different setting is needed to eliminate driveshaft vibes)  
Recommended toe in setting: 0 degrees.

\* Re-torque all fasteners, including lug nuts, after 100 miles, and frequently inspect all safety critical suspension components.



# IRON ROCK OFF ROAD

2-5/8" IRO Flex End (6 bolt)  
Assembly Instructions

1-877-919-JEEP www.ironrockoffroad.com

*Fits All Iron Rock Off Road Long Arm Systems, WJ A-Arms, and Build Your Own Flex End Assemblies.*

## Before you begin:

- o Read and understand installation instructions.
- o Contact Iron Rock Off Road with any questions before, during, or after installation.
- o **Ensure that all parts are present and in good condition per attached shipping checklist!**
- o Have these tools handy:
  - o 5/32" Allen head socket
  - o 3/8" open end wrench
  - o Inch-lb. torque wrench
  - o Multipurpose grease/grease gun

## Parts Checklist:

- Outer housing, weld on (may already be attached to your existing control arm)

## #127 - 2-5/8" IRO Flex End (6 bolt)

- 2-5/8" flex end race 91118 (2)
- Thrust washer 91119 (2)
- 2-5/8" flex end ball 91117 (1)
- #10-32 nylock nut (7)
- #10-32 x 1-3/4" socket head cap screw (6)
- 90° 1/4"-28 grease zerk fitting (1)

## Assembly:

1. Insert two #10-32 socket head cap screws into one thrust washer and one plastic race. Spherical bore of race facing away from thrust washer. (Figure 1)
2. Install this small assembly into the flex end housing. The races are a light press fit, use a wide punch and hammer to assist you if needed.
3. Apply a thin coating of multi-purpose grease to the mating surfaces of the ball and both races.
4. Place the ball in the race (inside the flex end). The ball should perfectly fit the contour of the race. (Figure 2)
5. Insert the other race onto the ball so that the spherical bore is contacting the ball. Once again, the races are a light press fit, use a hammer and wide punch if needed. (The two screws should be through one washer and both races at this point)
6. Insert the second thrust washer on top of the flex end housing, sliding the bolts through the holes. (Figure 3)
7. Start nylock nuts on the two bolts that are in the flex end assembly. Hold the nut and turn the bolt.
8. Insert the remaining four cap screws through the remaining holes and install nuts. (Figure 4)
9. Snug up all of the bolts fairly tight.
10. Torque bolts evenly, starting at one bolt and continuing using a crisscross pattern. Torque all six bolts to 70 in-lbs., then to 85 in-lbs.
11. Install 90° grease zerk fitting so that it is easily accessed in the vehicle.
12. Grease flex end until grease comes out of the races around the ball.
13. Re-torque bolts to 85 in-lbs. after 5 minutes.

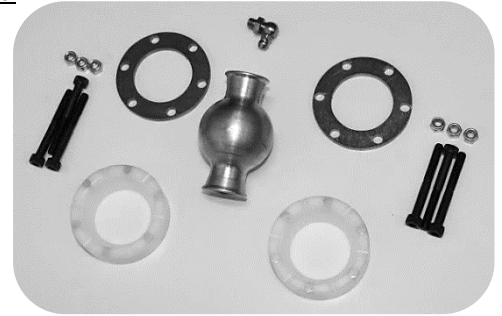

Figure 1

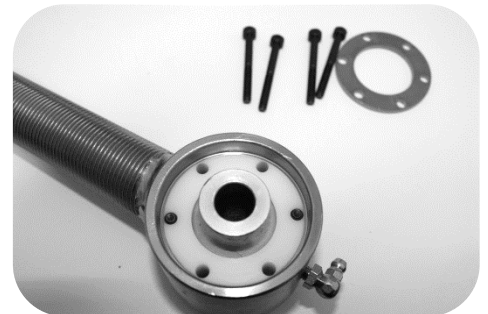

Figure 2



*\*Reference Only\* Complete joint shown fully assembled without housing*



Figure 3

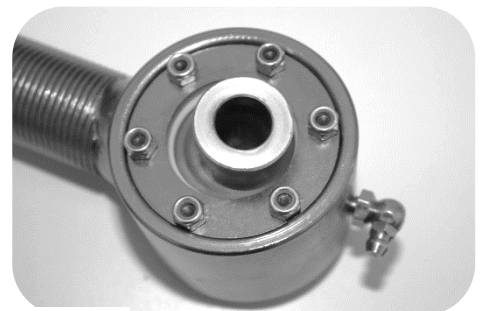

Figure 4

# IRON ROCK OFF ROAD

I-877-919-JEEP www.ironrockoffroad.com

## Track Bar Flex End Assembly Instructions

### Parts Checklist:

#### #122 - Track Bar Flex End - 12mm (1)

- Inner race (plastic) 91113 (2)
- End cap (steel) 91112 (2)
- Ball 91104 – M12 bolt (1)
- #5-40 x 1 1/4" Socket head cap screw (9)
- 3/32" Hex L key, hi torque (hex plus) (1)

#### #254 - Track Bar Flex End - 14mm (1)

- Inner race (plastic) 91113 (2)
- End cap (steel) 91112 (2)
- Ball 91142 – M14 bolt (1)
- #5-40 x 1 1/4" Socket head cap screw (9)
- 3/32" Hex L key, hi torque (hex plus) (1)



### Safety Warning:

Installation and assembly of this part requires knowledge of steering and suspension systems. Failure to precisely adhere to installation procedure may cause a part failure resulting in vehicle damage and serious injury or death. This part only fits Iron Rock Off Road track bars in good condition. Iron Rock Off Road makes no claims that this part will fit track bars from other manufacturers. Improper fitment may cause a part failure resulting in vehicle damage, serious injury, or death.

### Before you begin:

- Read and understand installation instructions.
- Contact Iron Rock Off Road with any questions before, during, or after installation.
- Ensure that all parts are present and in good condition per attached shipping checklist!
- Ensure that you have high strength threadlocker (such as red Loctite) and multi-purpose grease.

### Fitment:

This kit replaces the poly bushings and inner sleeve in your Iron Rock Off Road track bar. This part only fits track bars manufactured by Iron Rock Off Road after 2009 with an inside diameter of 1.510", a width of 1.250", and a radiused inside corner.

**\*\*\*To verify fitment: Remove the track bar from your vehicle, remove the poly bushings, clean the parts, and verify the following is true: \*\*\***

- The plastic races fit tight inside the inside bore.
- Both end caps fit the inside bore with just a bit of "wobble room".
- Both end caps slide in freely until the flat shoulder rests firmly against the end of the outer tube.
- The overall width of the outer tube is 1.250". This can be measured with a caliper or verified after flex end is fully assembled. Once fully assembled (bolts torqued to spec.) the shoulders of the end caps should rest firmly against the ends of the outer tube. At the same time, the ball should fit tight inside the assembly. It should require a tool (such as a screwdriver) to pivot or rotate the ball. The ball should pivot smoothly with even resistance in any position.



If any of those steps cannot be verified, please contact us to order a new track bar.

Bolt size: This bushing replacement assembly is only available to fit a 12mm & 14mm bolt at this time. Those with a 10mm fastener may wish to upgrade to 12mm hardware for more strength (drill your bracket and install a 12mm bolt).

### Assembly:

1. Verify fitment per the "Fitment" section above.
2. Insert four socket head cap screws into one end cap and one race. (Race should have spherical bore facing away from end cap.)
3. Install this small assembly into the track bar outer bushing tube. The races are a light press fit, use a wide punch and hammer to assist you if needed.
4. Apply a thin coat of multi-purpose grease to the ball and the spherical mating surface of the races. Coat both mating surfaces but leave no excess grease that would interfere with the threadlocker adhesive on the bolts.
5. Place the ball into the race inside the housing. The ball should fit the contour of the race perfectly.
6. Insert the other race on top of the ball so that the spherical bore is contacting the ball. Once again, the races are a light press fit, use a hammer and wide punch if needed. (The four screws should be through one end cap and both races at this point.)
7. Apply a generous coating of high strength threadlocker (such as red Loctite) to all 8 screws (including the ones already installed).
8. Install the second end cap, aligning the screws with the tapped holes. When completed 4 screws will be inserted from each side.
9. Insert the last four screws and tighten them all snug.
10. Torque screws in sequence using a crisscross pattern, like torquing lug nuts. Tighten all 8 screws evenly in small steps. Take your time and do not rush. Tighten all 8 screws to 20 in/lbs.



# IRON ROCK OFF ROAD

Sway Bar Disconnect  
Links Instructions

1-877-919-JEEP www.ironrockoffroad.com

## Parts List:

### #268 – Sway Bar Disconnect Bushings (1)

- ❑ Poly Bushing 94025 (4)

### WJ ~Optional~

#### #267 – WJ Sway Bar Disconnect Hardware (1)

- ❑ Disconnect Pin 94028 (2)
- ❑ Spacer Sleeve 94032 (2)
- ❑ 1/2-20 x 2-1/2" Hex Bolt, gr8 (2)
- ❑ 1/2 F436 Hard Washer (2)
- ❑ 1/4" x 1-1/4" Spring Lynch Pin (2)

#### #288 – WJ Sway Bar Disconnect Sleeves (1)

- ❑ 12mm bushing sleeve 92038 (2)

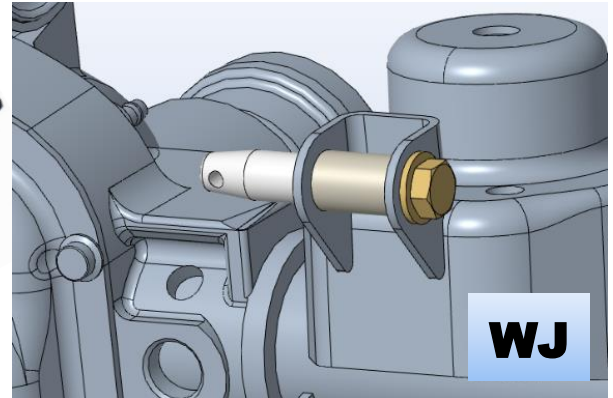
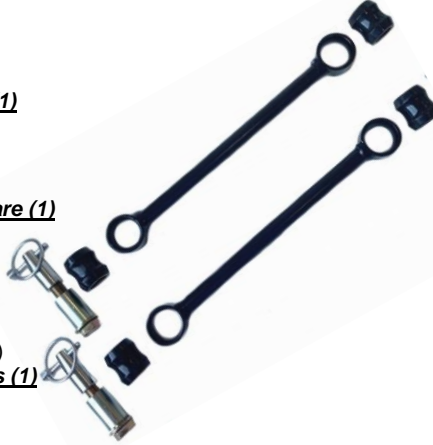

### JK ~Optional~

#### #266 – JK Sway Bar Disconnect Hardware (2)

- ❑ Disconnect Pin 94028 (2)
- ❑ 1/2-20 x 1" Hex Bolt, gr8 (2)
- ❑ 1/2 F436 Hard Washer (2)
- ❑ 1/4" x 1-1/4" Spring Lynch Pin (2)

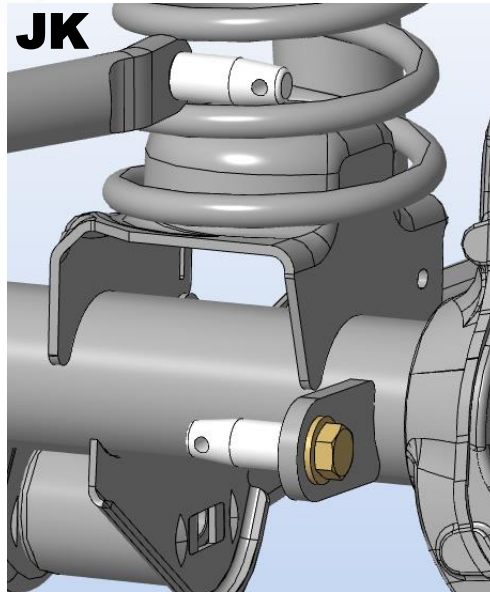

### XJ ~Optional~

#### #287 – XJ Sway Bar Disconnect Hardware (1)

- ❑ Disconnect Pin 94028 (2)
- ❑ 1/2-20 x 1" Hex Bolt, gr8 (2)
- ❑ 1/2 F436 Hard Washer (2)
- ❑ 1/4" x 1-1/4" Spring Lynch Pin (2)
- ❑ 12mm bolt sleeve 92038 (2)
- ❑ M12 x 70 cl10.9 hex bolt (2)
- ❑ M12 cl10.9 hex nut (2)
- ❑ 1/2 x 1 1/2" gr8 hex bolt (2)
- ❑ 1/2 gr8 lock washer (2)
- ❑ 1/2 gr8 hex nut (2)
- ❑ U-Bracket 99000 (2)



### TJ & ZJ ~Optional~

#### #286 – TJ & ZJ Sway Bar Disconnect Hardware (1)

- ❑ Disconnect Pin 94028 (2)
- ❑ 1/2-20 x 1" Hex Bolt, gr8 (2)
- ❑ 1/2 F436 Hard Washer (2)
- ❑ 1/4" x 1-1/4" Spring Lynch Pin (2)
- ❑ 12mm bolt sleeve 92038 (2)
- ❑ M12 x 60 hex bolt, cl10.9 (2)
- ❑ M12 hex nut, cl10.9 (2)
- ❑ M10 x 30 hex bolt, cl10.9 (2)
- ❑ 3/8" USS washer (2)
- ❑ M10 hex nut, cl10.9 (2)
- ❑ U-Bracket 99000 (2)

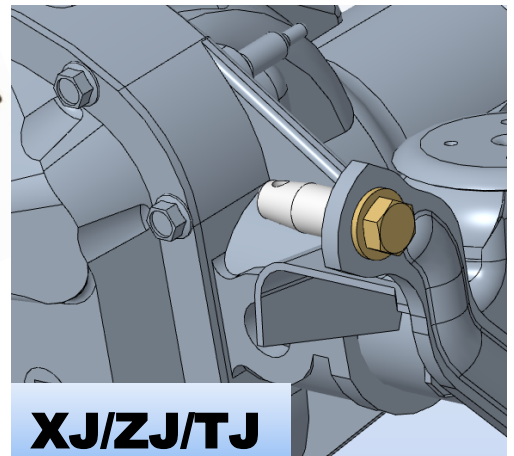
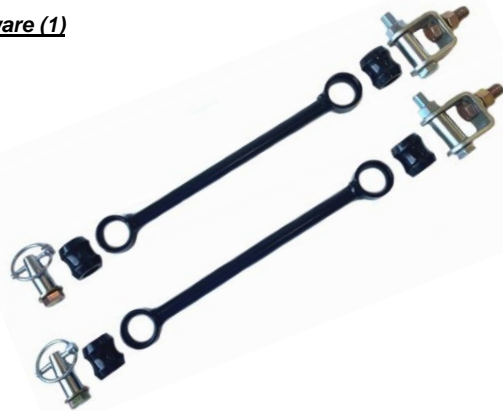

## Installation Instructions:

**Safety Warning: \*Important! Read before installation. \***

We recommend this system be installed by a qualified professional. Knowledge of suspension component function is necessary for safe installation and post installation inspections. Be sure to re-torque all suspension components after the first 100 miles of use, and frequently inspect all safety critical suspension components frequently.

## Notes:

- ❑ Do not operate vehicle with only one side of the sway bar connected. Both sides of the sway bar must either be disconnected or both sides must be connected.



## **Before you begin:**

- Read all safety warnings.
- Read and understand installation instructions.
- Contact Iron Rock Off Road with any questions before, during, or after installation. 952-210-7185
- Ensure that all parts are present and in good condition using the included shipping checklist.**
- Be sure you have the following tools and supplies:
  - Floor jack and jack stands.
  - Basic hand tools (wrenches, sockets, etc.).
  - Multi-purpose grease

## **Prepare for installation:**

1. Locate the front sway bar links, bushings, and bolt sleeves.
2. Grease and install the hourglass bushings.
3. Grease and install the sway bar link inner sleeves in only one end of each link.
4. Raise the vehicle and secure on jack stands under the frame.
5. Remove the front tires.
6. Disconnect the original front sway bar links from the axle and sway bar.

## **XJ Installation:**

7. Locate front sway bar links, two u-brackets, and **HK #287**.
8. Install sway bar link u-brackets to the sway bar using 1/2 x 1-1/2" grade 8 hex bolts, lock washers, and nuts. Brackets mount to the bottom of the sway bar with the bolt facing up and the lock washer and nut on top of the sway bar. Rotate the bracket so it is offset away from the center of the vehicle. Align brackets, torque bolts to 80 ft-lbs.
9. Install sway bar links driver's side first using provided M12 x 60mm class 10.9 hex bolt and nut through the u-bracket with the nuts toward the outside of the vehicle. Tighten all bolts to 78 ft-lbs.
10. Install the disconnect pin on the axle, pin pointing in-board. Use the 1/2" x 1" bolt with a washer.  
Tip: Before tightening determine your desired orientation for the retaining pin.
11. Hold the disconnect pin in your desired orientation and torque the bolt to 70lb-ft.
12. Apply grease to the disconnect pin and slide the sway bar link onto the disconnect pin.
13. Secure the sway bar link in place using the spring lynch pin.  
**\*NOTE:** The spring lynch pin should take some effort to install. This is done on purpose to keep the link secure and noise free.
14. Reinstall tires and torque lug nuts to spec.
15. Lower vehicle to the ground.
16. With the vehicle back on the ground, pull the spring pins and slip the sway bar links off the disconnect pins.
17. Swing the sway bar links up to the sway bar then swing the sway bar up to its highest position.
18. Flex the suspension and steer fully left and right. Check for possible interference between the tires and sway bar.
19. Reconnect the sway bar links to the axle.
20. For ease of installation and best performance, re-grease the sway bar bushings periodically.

## **ZJ and TJ Installation:**

21. Locate front sway bar links, two u-brackets, and **HK #286**.
22. Install sway bar link u-brackets to the sway bar using M10 x 30 hex bolts nuts and washers. Brackets mount to the bottom of the sway bar with the bolt facing up and the washer and nut on top of the sway bar. Align brackets with offset holes pushing the brackets toward the outside of the vehicle. Torque to 60 ft-lb.
23. Install sway bar links driver's side first using provided M12 x 60mm class 10.9 hex bolt and nut through the u-bracket with the nuts toward the outside of the vehicle. Tighten all bolts to 78 ft-lb.
24. Install the disconnect pin on the axle, pin pointing in-board. Use the 1/2" x 1" bolt with a washer.  
Tip: Before tightening determine your desired orientation for the retaining pin.
25. Hold the disconnect pin in your desired orientation and torque the bolt to 70lb-ft.
26. Apply grease to the disconnect pin and slide the sway bar link onto the disconnect pin.
27. Secure the sway bar link in place using the spring lynch pin.  
**\*NOTE:** The spring lynch pin should take some effort to install. This is done on purpose to keep the link secure and noise free.
28. Reinstall tires and torque lug nuts to spec.
29. Lower vehicle to the ground.
30. With the vehicle back on the ground, pull the spring pins and slip the sway bar links off the disconnect pins.
31. Swing the sway bar links up to the sway bar then swing the sway bar up to its highest position.
32. Flex the suspension and steer fully left and right. Check for possible interference between the tires and sway bar.
33. Reconnect the sway bar links to the axle.
34. For ease of installation and best performance, re-grease the sway bar bushings periodically.

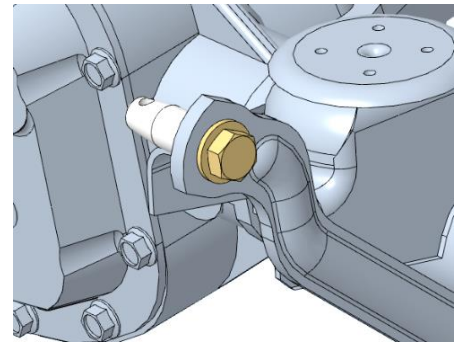
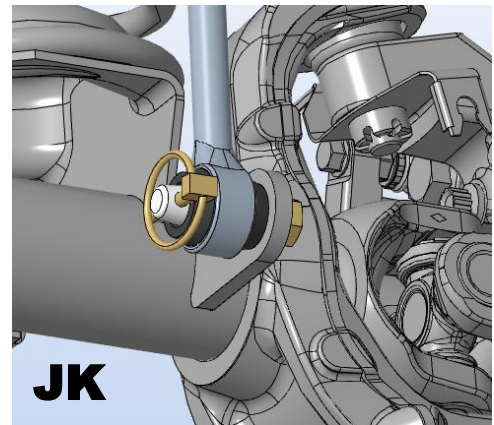

## **WJ Installation:**

35. Install the sway bar links onto the sway bar using the original hardware.
36. Install the disconnect pin on the axle, pin pointing in-board, spacer sleeve inside the mount.  
Use the 1/2" x 2-1/2" bolt with a washer.  
Tip: Before tightening determine your desired orientation for the retaining pin.
37. Hold the disconnect pin in your desired orientation and torque the bolt to 70lb-ft.
38. Install the new bushings into your sway bar links using plenty of multi-purpose grease.
39. Reinstall your sleeves into the top of the sway bar link bushing using multi-purpose grease.
40. Reinstall your sway bar link onto the sway bar and torque the bolts to 70lb-ft.
41. Apply grease to the disconnect pin and slide the sway bar link onto the disconnect pin.
42. Secure the sway bar link in place using the spring pin.  
**\*NOTE:** The spring pin should take some effort to install. This is done on purpose to keep the link secure and noise free.
43. Reinstall tires and torque lug nuts to spec.
44. Lower vehicle to the ground.
45. With the vehicle back on the ground, pull the spring pins and slip the sway bar links off the disconnect pins.
46. Swing the sway bar links up to the sway bar then swing the sway bar up to its highest position.
47. Flex the suspension and steer fully left and right. Check for possible interference between the tires and sway bar.
48. Reconnect the sway bar links to the axle.
49. For ease of installation and best performance, re-grease the sway bar bushings periodically.

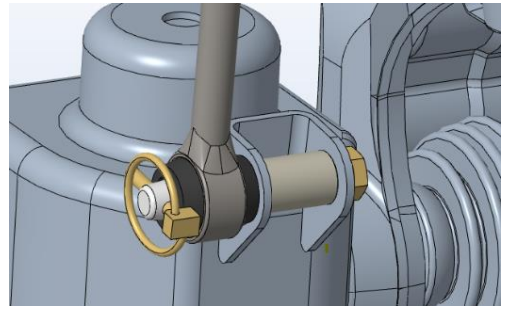

## **JK Installation:**

50. Use a 1/2" drill bit to slightly enlarge the bolt hole in the sway bar. Only a very minor amount of material will be removed.
51. Install the disconnect pin on the axle, pin pointing in-board. Use the 1/2" x 1" bolt with a washer.
52. Install the disconnect pin on the sway bar, pin pointing out-board. Use the 1/2" x 1" bolt with a washer.  
Tip: Before tightening determine your desired orientation for the retaining pin.
53. Hold the disconnect pin in your desired orientation and torque the bolts to 70lb-ft.
54. Install the bushings into the sway bar links using plenty of multi-purpose grease.
55. Apply grease to the disconnect pins and slide the sway bar link onto the disconnect pins.  
**\*NOTE:** Twist the passenger side link onto the lower pin first, then slide it onto the upper pin. It is a snug fit with the factory track bar bracket, but it is achievable.
56. Secure the sway bar link in place using the spring pins.  
**\*NOTE:** The spring pin should take some effort to install. This is done on purpose to keep the link secure and noise free.
57. Reinstall tires and torque lug nuts to spec.
58. Lower vehicle to the ground.
59. With the vehicle back on the ground, pull the spring pins and slip the sway bar links off the disconnect pins.
60. Swing the sway bar up to its highest position.
61. Flex the suspension and steer fully left and right. Check for possible interference between the tires and sway bar.
62. Reconnect the sway bar links to the axle.
63. For ease of installation and best performance, re-grease the sway bar bushings periodically.

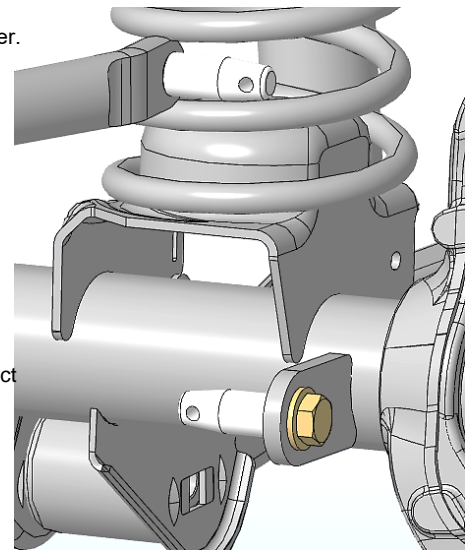

## **Final Safety Warning:**

**\*Both sides of the sway bar must be disconnected. Do not operate vehicle with only one side of the sway bar connected.**

Re-torque all fasteners after 100 miles, and frequently inspect all safety critical suspension components. It is the responsibility of the installer to ensure all fasteners are properly tightened after installation and to ensure the owner knows his/her ongoing responsibility. It is the responsibility of the owner of the vehicle to be sure all safety critical components are inspected frequently, especially after off road or other demanding use.

