

IRON ROCK OFF ROAD

ZJ 4.5" Premium Short Arm Lift Kit Installation Instructions ZJ 93-98 Jeep Grand Cherokee

Parts Checklist:

- Iron Rock Off Road logo decal (1)
- ironrockoffroad.com decal (1)
- ZJ 4.5" front spring 96029 (2)
- ZJ 4.5" rear spring 96017 (2)
- Rear sway bar link #007 (2)
- ZJ transfer case drop spacer 99003 (2)
- Double shear track bar bracket 91015 (1)
- Adjustable front upper control arm 99068 (2)
 - Front UCA Threaded Male End 99067 (2)
 - 1-14 Jam Nut (2)
 - Bushing installed (2)
- Adjustable rear upper control arm 99069 (2)
 - Rear UCA Threaded Male End 99063 (2)
 - 1-14 Jam Nut (2)
 - Bushing installed (4)

#11 - Front Brake Line Relocation

- 1/4" x 1" self-drilling sheet metal screw (2)

#12 - Transfer Case Drop

- M10x60 hex bolt, cl10.9 (4)
- 3/8" flat washer (4)

#66 - Front Control Arm Spacers

- Control arm spacer 90194 (2)

#274 - ZJ Rear Shock Spacer Hardware (1)

- Spacer 99170 (2)

~Standard Front Sway Bar Links~

- 8.75" Front sway bar link 92145 (2)

#58 - ZJ Sway Bar Link Hardware (1)

- 3/4" I.D. hourglass shock bushings 94025 (4)
- 12mm I.D. sway bar bolt sleeves 92038 (4)
- 12mm x 60mm class 10.9 ba1hex bolt (2)
- 12mm class 10.9 hex nut (2)
- M10 x 30 cl10.9 hex bolt (2)
- 3/8 USS washer (2)
- M10 cl10.9 hex nut (2)
- Sway bar link u-bracket 99000 (2)

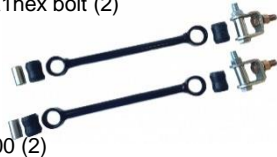

~Optional Front Sway Bar Disconnect Upgrade~

- 8.75" Front sway bar link 92145 (2)

#268 - Sway Bar Disconnect Bushings (1)

- Poly Bushing 94025 (4)

#286 - ZJ Sway Bar Disconnect Hardware (1)

- Disconnect Pin 94028 (2)
- 1/2-20 x 1" Hex Bolt, gr8 (2)
- 1/2 F436 Hard Washer (2)
- 1/4" x 1-1/4" Spring Lynch Pin (2)
- 12mm bolt sleeve 92038 (2)
- M12 x 60 hex bolt, cl10.9 (2)
- M12 hex nut, cl10.9 (2)
- M10 x 30 hex bolt, cl10.9 (2)
- 3/8" USS washer (2)
- M10 hex nut, cl10.9 (2)
- U-Bracket 99000 (2)



Standard Rubber Bushing Lower Control Arms (Front or Rear)

- Adjustable bent lower control arm, bushing installed 99169B (2 or 4)
- LCA Threaded Male End, bushing installed 99070 (2 or 4)

#65 - Adjustable LCA Clamping Hardware (1 or 2)

- 1/4"-28 x 1-1/8" socket head cap screw (4)
- 1/4"-28 hex nut, gr8 (4)



Optional Flex Joint Lower Control Arms (Front or Rear)

- Adjustable bent lower control arm, bushing installed 99169B (2 or 4)
- LCA Threaded Male End 92186 (2 or 4)

#65 - Adjustable LCA Clamping Hardware (1 or 2)

- 1/4"-28 x 1-1/8" socket head cap screw (4)
- 1/4"-28 hex nut, gr8 (4)

#127 - 2 5/8" 6 Bolt IRO Flex End Hardware (2 or 4)

- Inner race 91118 (2)
- Thrust washer 91119 (2)
- 2-5/8" Flex End Ball 91117 (1)
- 10-32 x 1-3/4" Socket Head Cap Screw (6)
- 10-32 Nylock Nut (6)
- 1/4"-28 90° Grease zerk Fitting (1)

- Double adjustable track bar 92305 (1)
- Double adjustable track bar male end 92297 (1)
- Double adjuster, track bar 91235 (1)



~Standard Front Track Bar~

#277 - XJ/ZJ Double Adjustable Track Bar Hardware (1)

- Track bar bushing half 80014 (4)
- 12mm track bar bushing sleeve 92035 (1)
- 7/16" I.D. track bar bushing sleeve 92036 (1)
- Track bar clamp 92303 (2)
- M12-1.75 x 80 hex bolt (2)
- M12-1.75 hex nut (2)
- 7/16" x 2-1/2" hex bolt, gr8 (1)
- 7/16" Track Bar Flag Nut 91230 (1)
- 7/16" USS flat washer (5)

~Optional Front Track Bar~

#122 - Track Bar Flex End Hardware - 12mm (2)

- Inner race (plastic) 91113 (2)
- End cap (steel) 91112 (2)
- Ball 91104 - M12 bolt (1)
- #5-40 x 1 1/4" Socket head cap screw (9)
- 3/32" Hex L key, high torque (hex plus) (1)

#277 - XJ/ZJ Double Adjustable Track Bar Hardware (1)

- Track bar bushing half 80014 (4)
- 12mm track bar bushing sleeve 92035 (1)
- 7/16" I.D. track bar bushing sleeve 92036 (1)
- Track bar clamp 92303 (2)
- M12-1.75 x 80 hex bolt (2)
- M12-1.75 hex nut (2)
- 7/16" x 2-1/2" hex bolt, gr8 (1)
- 7/16" Track Bar Flag Nut 91230 (1)
- 7/16" USS flat washer (5)

- ZJ adjustable rear track bar 99083 (1)
- Track bar male threaded end 92004 (1)



~Standard Rear Track Bar~

#13 – Rear Track Bar Hardware (1)

- Track bar bushing half 80014 (4)
- 12mm TB bushing sleeve 92035 (2)
- M12-1.75 x 70 hex bolt cl10.9 (1)
- M12-1.75 hex nut cl10.9 (1)
- 7/8-14 hex jam nut (1)

~Optional Premium Rear Track Bar~

#300 – TJ Premium Rear Track Bar Hardware (1)

- M12-1.75 x 70 hex bolt cl10.9 (1)
- M12-1.75 hex nut cl10.9 (1)
- 7/8-14 hex jam nut (1)

#122 - Track Bar Flex End Hardware - 12mm (2)

- Inner race (plastic) 91113 (2)
- End cap (steel) 91112 (2)
- Ball 91104 – M12 bolt (1)
- #5-40 x 1 1/4" Socket head cap screw (9)
- 3/32" Hex L key, high torque (hex plus) (1)

Shocks

Trail Tamer HD Hydro (Standard)

- Front shock 79002 (2)
- Rear shock 79005 (2)

Doetsch Upgrade (Optional)

- Front shock DT 8386 (2)
- Rear shock DT 8371 (2)

#9 – Shock Hardware (1)

- 2.5" Front shock barpin 403876 (2)

Bilstein Upgrade (Optional)

- Front shock 33-230375 (2)
- Rear shock 33-104652 (2)

#9 – Shock Hardware (1)

- 2.5" Front shock barpin 403876 (2)



Installation Instructions:

Safety Warning: ***Important! Read before installation.***

Installing a suspension lift kit raises the center of gravity of the vehicle. This increases the possibility of a rollover accident. Avoid sudden maneuvers at high speed and avoid all situations where a side rollover may occur. In addition, larger tires decrease braking performance, please drive accordingly. We recommend a tire and wheel combination that makes the vehicle's track width wider (wheels with less backspacing). This will lower the center of gravity and add stability. We also recommend that this system be installed by a qualified professional. Knowledge of suspension component function is necessary for safe installation and post installation inspections. Be sure to re-torque all suspension components after the first 100 miles of use, and frequently inspect all safety critical suspension components.

Before you begin:

- Read all safety warnings.
- Read and understand installation instructions.
- A coil spring compressor will make installation easier but is not required. You may wish to rent or buy one if you don't have one.
- Check all steering and suspension components for wear and replace as needed.
- Ensure that all parts are present and in good condition per attached shipping checklist.
- Contact Iron Rock Off Road with any questions before, during, or after installation.

Prepare parts for installation:

1. Locate track bar, track bar male threaded end, track bar bracket, double adjuster, and **HK #277**. Install clamps onto the double adjuster. ****If you upgraded to the Premium Track Bar refer to the instructions at the end of this document. Install flex joint into frame end of track bar.**
2. Apply anti-seize to all the threads then thread the track bar and male end into the double adjuster. Ensure the ends are equally threaded into the double adjuster then adjust the length to 33-5/8" center to center as a starting point.
3. Apply multi-purpose grease to both poly bushings and both inner bushing sleeves. Install bushings then sleeves into the track bar. The sleeve with the larger hole goes into frame side. (Longer end)
4. Locate adjustable control arms: Install jam nuts, apply anti-seize to all threads, then adjust length. Lower control arms are the same part for front or rear, they will be adjusted to different lengths. If you upgraded to the Flex Joints refer to the instructions at the end of this document.

Front suspension:

5. Lift front of vehicle and support with tall jack stands under the unibody frame.

Tip: break lug nuts loose before lifting vehicle if necessary.

6. Ensure that vehicle is safely supported.
7. Remove front tires.
8. Support front axle with a floor jack (do not lift vehicle).
9. Remove front shocks.
10. Remove front sway bar links.
11. Remove front track bar and the bracket that attaches track bar to unibody.
12. Remove nuts from all upper and lower control arms (front suspension only).
13. Remove upper and lower control arm on one side.
14. Allow axle to droop as much as possible.
15. Remove front coil spring clamps.
16. Remove front coil spring and install new one on the side with no control arms.
17. Install new upper control arm. Use the outer (forward) hole at the axle side.
18. Install new 16.25" lower control arm with the bend at the axle side hanging down (to clear shock mount at full droop). Place one control arm spacer from **HK #66** at the unibody side to push the control arm in away from the tire. Do not tighten bolts at this time.
19. Ensure male ends are parallel with control arm mounts then torque lower control arm clamping bolts to **140 in-lb**. Be sure to go back and forth between both bolts several times to ensure even clamping.
20. Repeat control arm and coil spring replacement process for the other side of the Jeep.
21. Install the track bar bracket onto the unibody with the factory bolts. Loosely attach the bracket with the upper two bolts, then align the lower bolt mounting holes. Install the lower mounting bolts and torque all track bar bracket hardware to 92 ft-lbs. *****NOTE:** If the unibody is rusty, the seam behind the factory bracket may have swelled making installation of the lower mounting bolts difficult. Using a ratchet strap to pull the bracket to align the holes or smoothing the seam with a hammer is recommended.
22. Install the track bar and torque bolt at axle to 74 ft-lbs., and bolt at bracket to 80 ft-lbs.
23. Locate front sway bar links (8.75" center to center), two u-brackets, and **HK #58**. If you upgraded to IRO Sway Bar Disconnect system, refer to the instructions at the end of this document.
24. Install sway bar link u-brackets to the sway bar using 1/2 x 1 1/2" grade 8 hex bolts, lock washers, and nuts. Brackets mount to the bottom of the sway bar with the bolt facing up and the lock washer and nut on top of the sway bar. Rotate brackets until offset toward outside of vehicle. Align brackets, torque bolts to 95 ft-lbs.

Control Arm Length (Starting Lengths - Center to Center)	
Front Lower Control Arms	16-1/4"
Front Upper Control Arms	15-1/2"
Rear Lower Control Arms	18-5/16"
Rear Upper Control Arms	14-7/8"

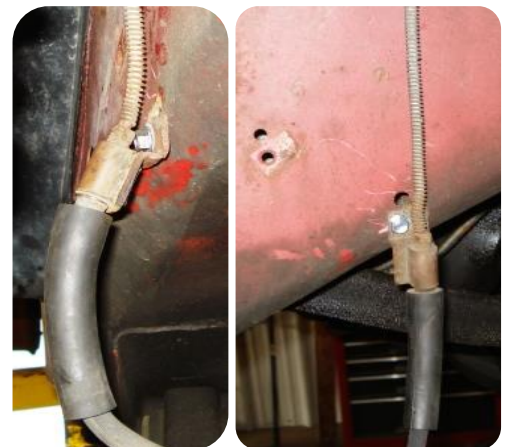

25. Lubricate sway bar link bushings and bushing sleeves with multi-purpose grease and install into sway bar links.
26. Install sway bar links driver's side first using provided M12 x 60mm hex bolt and nut through the u-bracket with the nuts toward the outside of the vehicle, and the original bolt, nut, and washer at the axle. Torque all nuts to 78 ft-lbs.
27. Locate **HK #11**.

28. On one side, remove the bolt that holds the brake hose to the unibody.
29. Pull brake line down as far as possible without over-stressing or causing a kink in the line. *Note: Your brake line may appear different from the photo. Do not pull too far and damage the brake line.
30. Using two adjustable wrenches bend brake line bracket mounting surface so brake line points out toward the brake caliper. See photo.
31. Mark location and drill a 1/4" hole for the brake line locating tab.
32. Fasten brake line to unibody using provided self-drilling sheet metal screw.
33. Repeat for other side.
34. Locate front shocks, and **HK #9**.
35. Install barpins into front shocks. Lubricate shock bushings and barpins with multi-purpose grease, clamp barpin vertically in a bench vise, and push shock onto barpin rotating the shock as you push down.
36. Install front shocks using original barpin bolts. Tighten upper stud mount nuts just enough to slightly compress the bushings. *Note: Over compressing these bushings will result in damage to the bushings and premature bushing failure.
37. Torque shock barpin bolts to 17 ft-lbs.
38. Any remaining loose bolts will be tightened after rear suspension is installed.

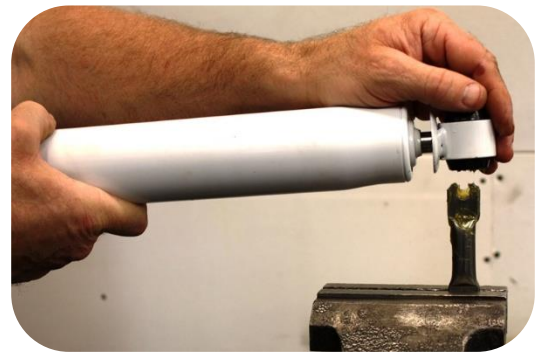

Rear Suspension:

39. Lift rear of vehicle and support with tall jack stands under the unibody frame.
Tip: break lug nuts loose before lifting vehicle if necessary.
40. Ensure that the vehicle is safely supported.
41. Remove rear tires.
42. Support rear axle with floor jack (do not lift vehicle).
43. Remove rear shocks.
44. Remove rear sway bar links.
45. Remove rear track bar (most ZJ's require a T55 Torx socket for the track bar bolts).
46. Remove all rear upper and lower control arm nuts.
47. Remove upper and lower control arm on one side.
48. Remove coil spring clamps.
49. Remove rear coil spring and install the provided new spring.
50. Install new lower control arm with bend at axle side, hanging down. Do not tighten bolts at this time.
51. Install new upper control arm. Do not tighten bolts at this time.
52. Repeat the control arm and coil spring replacement process for the other side of the Jeep.
53. Locate rear track bar and **HK #13**.
54. Lubricate track bar bushings and bushing sleeves with multi-purpose grease and install. Install jam nut onto threaded end of track bar, adjust the length to 31-3/4" center to center.
55. Using provided new bolts and nut, install the track bar with the thread adjusting end on the axle side. The bend on the opposite side goes up and over the exhaust.
56. Torque track bar bolts to 78 ft-lbs.
57. Install 12mm I.D. sleeves into lower (body) end of rear shocks (opposite end from shock shaft). Lubricate shock bushings and 12mm I.D. sleeves with multi-purpose grease and press the sleeves into the shock bushings.
58. Lubricate upper shock bushings and upper shock mounting studs on the vehicle with multi-purpose grease. No sleeve is needed in the upper shock bushing.
59. Install spacer from **HK #274** on upper rear shock stud then install rear shocks with shock body down. Torque upper nuts to 46 ft-lbs., and lower nuts to 80 ft-lbs.
60. Raise vehicle and relocate the jack stands under the front and rear axles so that the vehicle's weight is on the suspension system.
61. Ensure that the vehicle is safely supported.
62. Install rear sway bar links with nuts facing down. Tighten nut until snug but do not compress the bushings, the spacer sleeve in the center of the link should still be able to be rotated by hand after tightening.
63. Install front and rear coil spring clamps.
64. Torque front and rear upper control nuts to 60 ft-lbs.
65. Torque front and rear lower control nuts to 120 ft-lbs.
66. Tighten any jam nuts very tight.
67. Torque any remaining loose bolts to spec.
68. Install tires.
69. Remove vehicle from jack stands.
70. Torque wheel lug nuts to spec. (usually 85-115 ft-lbs., verify using factory service manual)

Transfer Case Drop Kit:

71. Locate transfer case drop spacers and **HK #12**.
72. Place a floor jack under the center of transfer case crossmember for support.
73. On one side remove the two bolts that hold the t-case crossmember to the unibody.
74. Lower t-case crossmember away from unibody.
75. Install spacer using new bolts and washers. Torque bolts to 50 ft-lbs.
76. Repeat for the other side.

Adjustments and Safety Inspection:

77. Check all components for clearance for suspension to fully cycle up and down and wheels to turn lock to lock. Pay special attention to brake line length and location of all brake lines, axle vent hoses, and ABS wires. Reposition as needed.
78. Check front and rear driveshafts for proper running length. Slight adjustments can be made by adjusting caster angle, otherwise different length control arms, or custom driveshafts may be required.
79. Go for a short test drive.
80. Ensure front axle is centered. Orient track bar clamps to not interfere with any other components. Tighten track bar clamps to 60 ft-lbs.
81. A professional front end alignment is required after installation. Your toe-in will be affected and may cause unpredictable steering and accelerated tire wear.

Recommended caster setting: +3.75 to +6.0 (+4.5 degrees is recommended unless a different setting is required for proper driveshaft running length)

Recommended toe in setting: 0 degrees

* Re-torque all fasteners, including lug nuts, after 100 miles, and frequently inspect all safety critical suspension components.



IRON ROCK OFF ROAD

2-5/8" IRO Flex End (6 bolt) Assembly Instructions

1-877-919-JEEP www.ironrockoffroad.com

Fits All Iron Rock Off Road Long Arm Systems, WJ A-Arms, and Build Your Own Flex End Assemblies.

Before you begin:

- Read and understand installation instructions.
- Contact Iron Rock Off Road with any questions before, during, or after installation.
- **Ensure that all parts are present and in good condition per attached shipping checklist!**
- Have these tools handy:
 - 5/32" Allen head socket
 - 3/8" open end wrench
 - Inch-lb. torque wrench
 - Multipurpose grease/grease gun

Parts Checklist:

- Outer housing, weld on (may already be attached to your existing control arm)

#127 - 2-5/8" IRO Flex End (6 bolt)

- 2-5/8" flex end race 91118 (2)
- Thrust washer 91119 (2)
- 2-5/8" flex end ball 91117 (1)
- #10-32 nylock nut (7)
- #10-32 x 1-3/4" socket head cap screw (6)
- 90° 1/4"-28 grease zerk fitting (1)

Assembly:

1. Insert two #10-32 socket head cap screws into one thrust washer and one plastic race. Spherical bore of race facing away from thrust washer. (Figure 1)
2. Install this small assembly into the flex end housing. The races are a light press fit, use a wide punch and hammer to assist you if needed.
3. Apply a thin coating of multi-purpose grease to the mating surfaces of the ball and both races.
4. Place the ball in the race (inside the flex end). The ball should perfectly fit the contour of the race. (Figure 2)
5. Insert the other race onto the ball so that the spherical bore is contacting the ball. Once again, the races are a light press fit, use a hammer and wide punch if needed. (The two screws should be through one washer and both races at this point)
6. Insert the second thrust washer on top of the flex end housing, sliding the bolts through the holes. (Figure 3)
7. Start nylock nuts on the two bolts that are in the flex end assembly. Hold the nut and turn the bolt.
8. Insert the remaining four cap screws through the remaining holes and install nuts. (Figure 4)
9. Snug up all of the bolts fairly tight.
10. Torque bolts evenly, starting at one bolt and continuing using a crisscross pattern. Torque all six bolts to 70 in-lbs., then to 85 in-lbs.
11. Install 90° grease zerk fitting so that it is easily accessed in the vehicle.
12. Grease flex end until grease comes out of the races around the ball.
13. Re-torque bolts to 85 in-lbs. after 5 minutes.

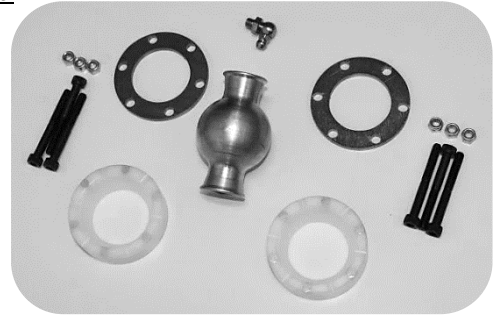

Figure 1

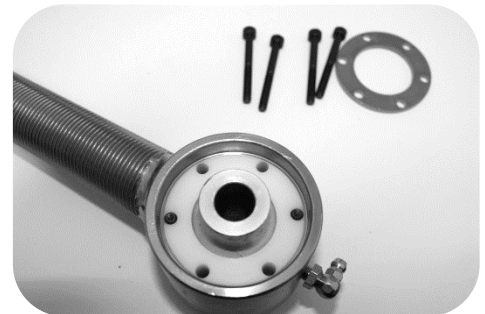

Figure 2



Figure 3

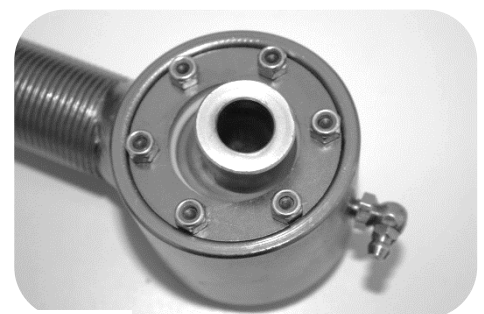

Figure 4

**Reference Only* Complete joint shown fully assembled without housing*

IRON ROCK OFF ROAD

Track Bar Flex End Assembly Instructions

1-877-919-JEEP www.ironrockoffroad.com

Parts Checklist:

#122 - Track Bar Flex End - 12mm (1)

- Inner race (plastic) 91113 (2)
- End cap (steel) 91112 (2)
- Ball 91104 – M12 bolt (1)
- #5-40 x 1 1/4" Socket head cap screw (9)
- 3/32" Hex L key, high torque (hex plus) (1)

#254 - Track Bar Flex End - 14mm (1)

- Inner race (plastic) 91113 (2)
- End cap (steel) 91112 (2)
- Ball 91142 – M14 bolt (1)
- #5-40 x 1 1/4" Socket head cap screw (9)
- 3/32" Hex L key, high torque (hex plus) (1)



Safety Warning:

Installation and assembly of this part requires knowledge of steering and suspension systems. Failure to precisely adhere to installation procedure may cause a part failure resulting in vehicle damage and serious injury or death. This part only fits Iron Rock Off Road track bars in good condition. Iron Rock Off Road makes no claims that this part will fit track bars from other manufacturers. Improper fitment may cause a part failure resulting in vehicle damage, serious injury, or death.

Before you begin:

- o Read and understand installation instructions.
- o Contact Iron Rock Off Road with any questions before, during, or after installation.
- o **Ensure that all parts are present and in good condition per attached shipping checklist!**
- o Ensure that you have high strength threadlocker (such as red Loctite) and multi-purpose grease.

Fitment:

This kit replaces the poly bushings and inner sleeve in your Iron Rock Off Road track bar. This part only fits track bars manufactured by Iron Rock Off Road after 2009 with an inside diameter of 1.510", a width of 1.250", and a radiused inside corner.

*****To verify fitment: Remove the track bar from your vehicle, remove the poly bushings, clean the parts, and verify the following is true: *****

- The plastic races fit tight inside the inside bore.
- Both end caps fit the inside bore with just a bit of "wobble room".
- Both end caps slide in freely until the flat shoulder rests firmly against the end of the outer tube.
- The overall width of the outer tube is 1.250". This can be measured with a caliper or verified after flex end is fully assembled. Once fully assembled (bolts torqued to spec.) the shoulders of the end caps should rest firmly against the ends of the outer tube. At the same time, the ball should fit tight inside the assembly. It should require a tool (such as a screwdriver) to pivot or rotate the ball. The ball should pivot smoothly with even resistance in any position.



If any of those steps cannot be verified, please contact us to order a new track bar.

Bolt size: This bushing replacement assembly is only available to fit a 12mm & 14mm bolt at this time. Those with a 10mm fastener may wish to upgrade to 12mm hardware for more strength (drill your bracket and install a 12mm bolt).

Assembly:

1. Verify fitment per the "Fitment" section above.
2. Insert four socket head cap screws into one end cap and one race. (Race should have spherical bore facing away from end cap.)
3. Install this small assembly into the track bar outer bushing tube. The races are a light press fit, use a wide punch and hammer to assist you if needed.
4. Apply a thin coat of multi-purpose grease to the ball and the spherical mating surface of the races. Coat both mating surfaces but leave no excess grease that would interfere with the threadlocker adhesive on the bolts.
5. Place the ball into the race inside the housing. The ball should fit the contour of the race perfectly.
6. Insert the other race on top of the ball so that the spherical bore is contacting the ball. Once again, the races are a light press fit, use a hammer and wide punch if needed. (The four screws should be through one end cap and both races at this point.)
7. Apply a generous coating of high strength threadlocker (such as red Loctite) to all 8 screws (including the ones already installed).
8. Install the second end cap, aligning the screws with the tapped holes. When completed 4 screws will be inserted from each side.
9. Insert the last four screws and tighten them all snug.
10. Torque screws in sequence using a crisscross pattern, like torquing lug nuts. Tighten all 8 screws evenly in small steps. Take your time and do not rush. Tighten all 8 screws to 20 in/lbs.

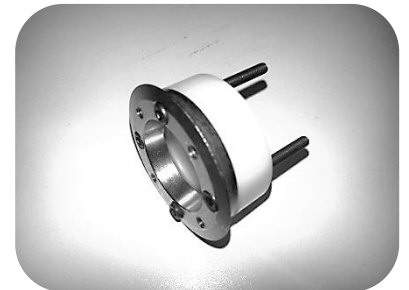

IRON ROCK OFF ROAD

1-877-919-JEEP www.ironrockoffroad.com

Sway Bar Disconnect
Links Instructions

Parts List:

#268 – Sway Bar Disconnect Bushings (1)

- Poly Bushing 94025 (4)

WJ ~Optional~

#267 – WJ Sway Bar Disconnect Hardware (1)

- Disconnect Pin 94028 (2)
- Spacer Sleeve 94032 (2)
- 1/2-20 x 2-1/2" Hex Bolt, gr8 (2)
- 1/2 F436 Hard Washer (2)
- 1/4" x 1-1/4" Spring Lynch Pin (2)

#288 – WJ Sway Bar Disconnect Sleeves (1)

- 12mm bushing sleeve 92038 (2)

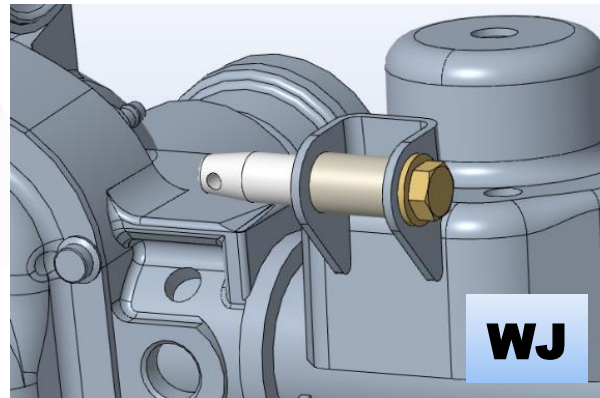
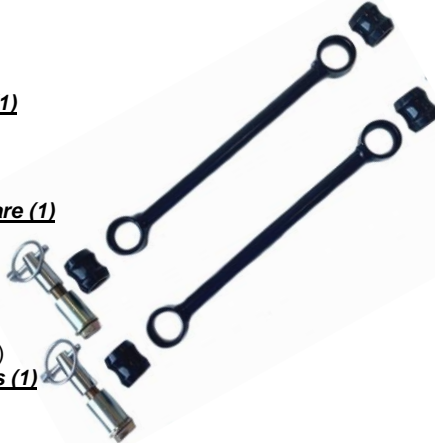

JK ~Optional~

#266 – JK Sway Bar Disconnect Hardware (2)

- Disconnect Pin 94028 (2)
- 1/2-20 x 1" Hex Bolt, gr8 (2)
- 1/2 F436 Hard Washer (2)
- 1/4" x 1-1/4" Spring Lynch Pin (2)

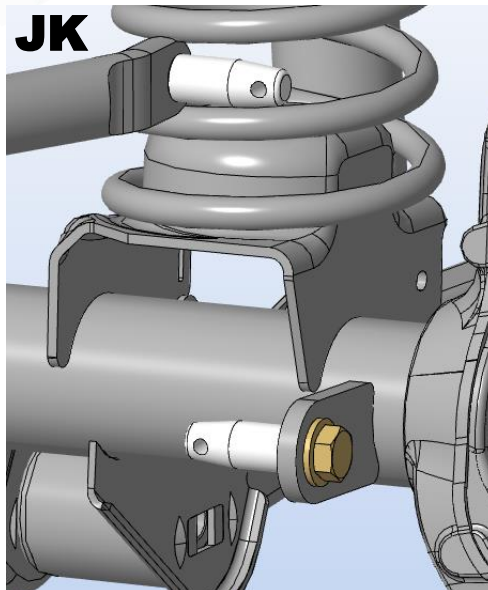

XJ ~Optional~

#287 – XJ Sway Bar Disconnect Hardware (1)

- Disconnect Pin 94028 (2)
- 1/2-20 x 1" Hex Bolt, gr8 (2)
- 1/2 F436 Hard Washer (2)
- 1/4" x 1-1/4" Spring Lynch Pin (2)
- 12mm bolt sleeve 92038 (2)
- M12 x 70 cl10.9 hex bolt (2)
- M12 cl10.9 hex nut (2)
- 1/2 x 1 1/2" gr8 hex bolt (2)
- 1/2 gr8 lock washer (2)
- 1/2 gr8 hex nut (2)
- U-Bracket 99000 (2)



TJ & ZJ ~Optional~

#286 – TJ & ZJ Sway Bar Disconnect Hardware (1)

- Disconnect Pin 94028 (2)
- 1/2-20 x 1" Hex Bolt, gr8 (2)
- 1/2 F436 Hard Washer (2)
- 1/4" x 1-1/4" Spring Lynch Pin (2)
- 12mm bolt sleeve 92038 (2)
- M12 x 60 hex bolt, cl10.9 (2)
- M12 hex nut, cl10.9 (2)
- M10 x 30 hex bolt, cl10.9 (2)
- 3/8" USS washer (2)
- M10 hex nut, cl10.9 (2)
- U-Bracket 99000 (2)

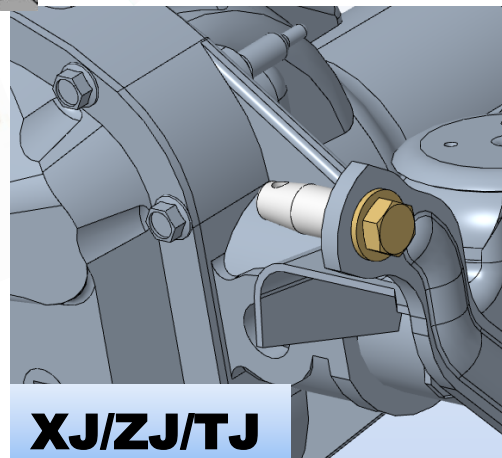
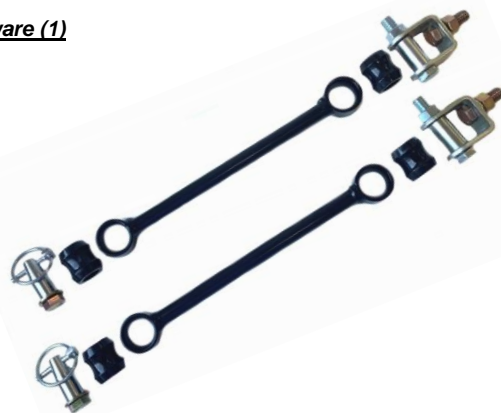

Installation Instructions:

Safety Warning: *Important! Read before installation. *

We recommend this system be installed by a qualified professional. Knowledge of suspension component function is necessary for safe installation and post installation inspections. Be sure to re-torque all suspension components after the first 100 miles of use, and frequently inspect all safety critical suspension components frequently.

Notes:

- Do not operate vehicle with only one side of the sway bar connected. Both sides of the sway bar must either be disconnected or both sides must be connected.

Before you begin:

- Read all safety warnings.
- Read and understand installation instructions.
- Contact Iron Rock Off Road with any questions before, during, or after installation. 952-210-7185
- Ensure that all parts are present and in good condition using the included shipping checklist.**
- Be sure you have the following tools and supplies:
 - Floor jack and jack stands.
 - Basic hand tools (wrenches, sockets, etc.).
 - Multi-purpose grease

Prepare for installation:

1. Locate the front sway bar links, bushings, and bolt sleeves.
2. Grease and install the hourglass bushings.
3. Grease and install the sway bar link inner sleeves in only one end of each link.
4. Raise the vehicle and secure on jack stands under the frame.
5. Remove the front tires.
6. Disconnect the original front sway bar links from the axle and sway bar.

XJ Installation:

7. Locate front sway bar links, two u-brackets, and **HK #287**.
8. Install sway bar link u-brackets to the sway bar using 1/2 x 1-1/2" grade 8 hex bolts, lock washers, and nuts. Brackets mount to the bottom of the sway bar with the bolt facing up and the lock washer and nut on top of the sway bar. Rotate the bracket so it is offset away from the center of the vehicle. Align brackets, torque bolts to 80 ft-lbs.
9. Install sway bar links driver's side first using provided M12 x 60mm class 10.9 hex bolt and nut through the u-bracket with the nuts toward the outside of the vehicle. Tighten all bolts to 78 ft-lbs.
10. Install the disconnect pin on the axle, pin pointing in-board. Use the 1/2" x 1" bolt with a washer.
Tip: Before tightening determine your desired orientation for the retaining pin.
11. Hold the disconnect pin in your desired orientation and torque the bolt to 70lb-ft.
12. Apply grease to the disconnect pin and slide the sway bar link onto the disconnect pin.
13. Secure the sway bar link in place using the spring lynch pin.
***NOTE:** The spring lynch pin should take some effort to install. This is done on purpose to keep the link secure and noise free.
14. Reinstall tires and torque lug nuts to spec.
15. Lower vehicle to the ground.
16. With the vehicle back on the ground, pull the spring pins and slip the sway bar links off the disconnect pins.
17. Swing the sway bar links up to the sway bar then swing the sway bar up to its highest position.
18. Flex the suspension and steer fully left and right. Check for possible interference between the tires and sway bar.
19. Reconnect the sway bar links to the axle.
20. For ease of installation and best performance, re-grease the sway bar bushings periodically.

ZJ and TJ Installation:

21. Locate front sway bar links, two u-brackets, and **HK #286**.
22. Install sway bar link u-brackets to the sway bar using M10 x 30 hex bolts nuts and washers. Brackets mount to the bottom of the sway bar with the bolt facing up and the washer and nut on top of the sway bar. Align brackets with offset holes pushing the brackets toward the outside of the vehicle. Torque to 60 ft-lb.
23. Install sway bar links driver's side first using provided M12 x 60mm class 10.9 hex bolt and nut through the u-bracket with the nuts toward the outside of the vehicle. Tighten all bolts to 78 ft-lb.
24. Install the disconnect pin on the axle, pin pointing in-board. Use the 1/2" x 1" bolt with a washer.
Tip: Before tightening determine your desired orientation for the retaining pin.
25. Hold the disconnect pin in your desired orientation and torque the bolt to 70lb-ft.
26. Apply grease to the disconnect pin and slide the sway bar link onto the disconnect pin.
27. Secure the sway bar link in place using the spring lynch pin.
***NOTE:** The spring lynch pin should take some effort to install. This is done on purpose to keep the link secure and noise free.
28. Reinstall tires and torque lug nuts to spec.
29. Lower vehicle to the ground.
30. With the vehicle back on the ground, pull the spring pins and slip the sway bar links off the disconnect pins.
31. Swing the sway bar links up to the sway bar then swing the sway bar up to its highest position.
32. Flex the suspension and steer fully left and right. Check for possible interference between the tires and sway bar.
33. Reconnect the sway bar links to the axle.
34. For ease of installation and best performance, re-grease the sway bar bushings periodically.

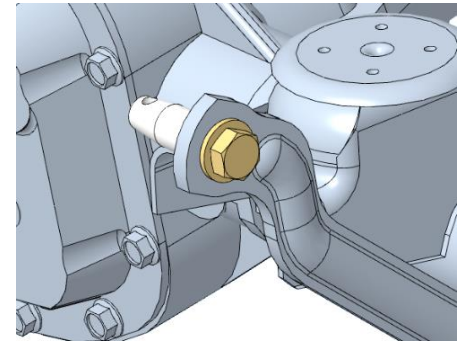
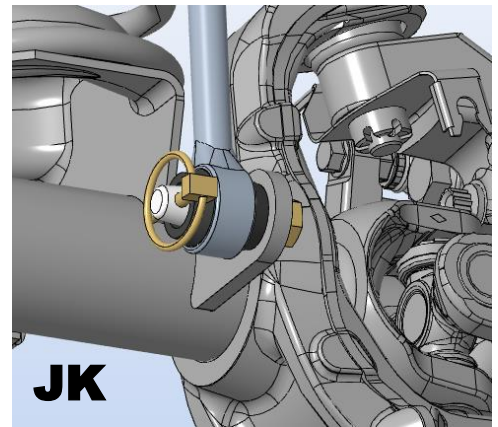

WJ Installation:

35. Install the sway bar links onto the sway bar using the original hardware.
36. Install the disconnect pin on the axle, pin pointing in-board, spacer sleeve inside the mount.

Use the 1/2" x 2-1/2" bolt with a washer.

Tip: Before tightening determine your desired orientation for the retaining pin.

37. Hold the disconnect pin in your desired orientation and torque the bolt to 70lb-ft.
38. Install the new bushings into your sway bar links using plenty of multi-purpose grease.
39. Reinstall your sleeves into the top of the sway bar link bushing using multi-purpose grease.
40. Reinstall your sway bar link onto the sway bar and torque the bolts to 70lb-ft.
41. Apply grease to the disconnect pin and slide the sway bar link onto the disconnect pin.
42. Secure the sway bar link in place using the spring pin.

***NOTE:** The spring pin should take some effort to install. This is done on purpose to keep the link secure and noise free.

43. Reinstall tires and torque lug nuts to spec.
44. Lower vehicle to the ground.
45. With the vehicle back on the ground, pull the spring pins and slip the sway bar links off the disconnect pins.
46. Swing the sway bar links up to the sway bar then swing the sway bar up to its highest position.
47. Flex the suspension and steer fully left and right. Check for possible interference between the tires and sway bar.
48. Reconnect the sway bar links to the axle.
49. For ease of installation and best performance, re-grease the sway bar bushings periodically.

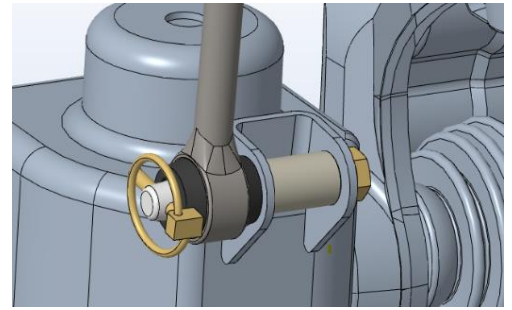

JK Installation:

50. Use a 1/2" drill bit to slightly enlarge the bolt hole in the sway bar. Only a very minor amount of material will be removed.
51. Install the disconnect pin on the axle, pin pointing in-board. Use the 1/2" x 1" bolt with a washer.
52. Install the disconnect pin on the sway bar, pin pointing out-board. Use the 1/2" x 1" bolt with a washer.

Tip: Before tightening determine your desired orientation for the retaining pin.

53. Hold the disconnect pin in your desired orientation and torque the bolts to 70lb-ft.
 54. Install the bushings into the sway bar links using plenty of multi-purpose grease.
 55. Apply grease to the disconnect pins and slide the sway bar link onto the disconnect pins.
- *NOTE:** Twist the passenger side link onto the lower pin first, then slide it onto the upper pin. It is a snug fit with the factory track bar bracket, but it is achievable.

56. Secure the sway bar link in place using the spring pins.
- *NOTE:** The spring pin should take some effort to install. This is done on purpose to keep the link secure and noise free.
57. Reinstall tires and torque lug nuts to spec.
58. Lower vehicle to the ground.
59. With the vehicle back on the ground, pull the spring pins and slip the sway bar links off the disconnect pins.
60. Swing the sway bar up to its highest position.
61. Flex the suspension and steer fully left and right. Check for possible interference between the tires and sway bar.
62. Reconnect the sway bar links to the axle.
63. For ease of installation and best performance, re-grease the sway bar bushings periodically.

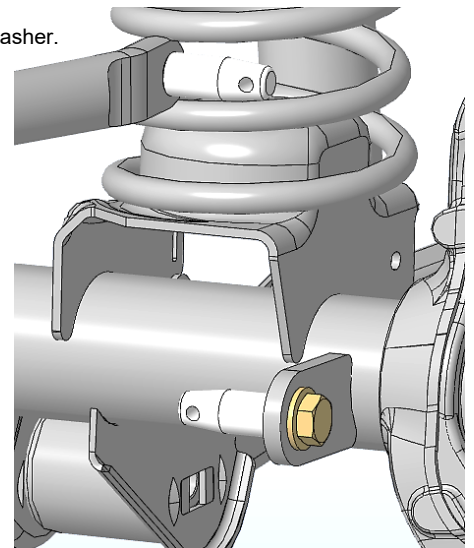

Final Safety Warning:

***Both sides of the sway bar must be disconnected. Do not operate vehicle with only one side of the sway bar connected.**

Re-torque all fasteners after 100 miles, and frequently inspect all safety critical suspension components. It is the responsibility of the installer to ensure all fasteners are properly tightened after installation and to ensure the owner knows his/her ongoing responsibility. It is the responsibility of the owner of the vehicle to be sure all safety critical components are inspected frequently, especially after off road or other demanding use.

